



SERVING
SAFETY

Mors Smitt Industrial Technology

High performance electromechanical relays

Protection and control for power transmission and distribution

Auxiliary · Tripping · Supervision · Pilot wire

 **Mors Smitt**
A Wabtec Company



SERVING
SAFETY

Mors Smitt Industrial Technology

High performance electromechanical relays



By focusing on products excellence for the industrial market, we contribute to a better environment, health and safety of all people involved

Mors Smitt - Industrial Technology

Mors Smitt has been manufacturing relays since 1902. Our wide relay portfolio is focused on markets sectors like; power generation & distribution, factory automation, petro-chemical and water treatment plants and general industrial requirements. Production is flexible, standards unforgiving. Many units are tailored to specific client requirements. All products go through extensive testing processes with both hardware and production methodology approved to the highest standards.

High performance protection and control

The Actus relays are a new generation of electro-mechanical relays specifically designed for high voltage protection and control applications. High performance and reliability remains paramount while production lead times have been reduced.

The Actus relays are packaged in a draw out case system and can be either flush panel or rack mounted. The effect of a fault on a power system is dependent on the speed with which the fault can be detected and isolated. The Actus model relay provides the interface between the protection system, the circuit breaker and control equipment. Application of the Actus multi contact high speed trip relays ensures fast operation of less than 8 ms. The unique patented design and topology ensures minimal contact bounce.

Safety and reliability

The effect of a fault on a power system is dependent on the speed with which the fault can be detected and isolated. Modern protection schemes incorporate ever increasing functionality through the application of digital techniques to protection relay technology. The requirement for high reliable tripping and control relay elements does however remain and often constitutes a significant cost and space requirement when considering protection panel designs. The Actus system provides a compact, flexible and high performance solution, while at the same time reducing the cost and lead times normally associated with this class of device.

A wide voltage operating range and user selectable low or high burden tripping relay operation reduces the number of model variations. Not just our products and services but also our production sites are focused on environmental performance improvements by certification according the ISO 9001:2008 and ISO 14001:2004.



Mors Smitt is part of Wabtec Corporation, the NYSE stock exchange listed, global supplier of highly engineered components and solutions for rail and selected industrial markets. Operations in 17 countries and world wide sales in over 100 countries. Wabtec Corporation holds over 1.200 patents and has world class internal processes based on lean manufacturing and continuous improvement principles (Wabtec Performance System).

Within the Wabtec group Mors Smitt has its own name & identity and is focused on satisfying the needs of customers in the power grid, industry and installation sectors.

Utrecht, November 2013

Mors Smitt B.V. continuous to improve its products and services. Specifications can be changed without prior notice. No rights can be derived from specifications in this brochure. Changes and printed errors reserved.

Content

Auxiliary, trip & supervision

New generation of electro-mechanical relays specifically designed for high voltage protection and control applications. Multi-contact high-speed trip relays ensures fast operation of less than 8 ms. The unique patented design and topology ensures minimal contact bounce.

		Page
MSTR	High speed tripping relay	10
MSAR	High performance auxiliary relay	11
MSXR	Supervision relay	12
MSPR	Pilot wire intertrip relay	13
MS1X50	CB trip & close module	14



Arc fault protection

Arc fault protection for the fast clearance of arcing faults on BUS bars & within metal clad switchgear & associated cable boxes.

		Page
MS1S20	Arc fault monitor	16
MS1S23	Arc fault interface module	17
MS1S24	Arc fault monitoring system IEC 61850	18
MS1S25	Arc fault monitor	19
MS1S30	Optical arc fault sensor	20



Test block & plug systems

Test links are an important accessory for protection, metering & control panels. They enable test technicians to quickly & safely isolate protection relays so that test signals may be injected & system performance verified.

		Page
MS4M400	Test block	22
MS4M420	Test plug	23
MS2RMLB-S	Multi-finger test plug	24
Accessories	Test plug accessories	25



Alarm panels

Alarm panels are an effective choice for the annunciation of alarms & operating events. The alarm points indicate an alarm situation of a specific application.

		Page
MS1A54	Alarm panel	28



Phase monitoring

Phase monitoring relays are suitable for the detection of excessive negative sequence voltage resulting from phase failure, phase unbalance or reversed phase sequence.

		Page
MS2P48	Potential selecting relay	30
MS2P49	Three phase voltage monitoring relay	31



Timers

Provide high accuracy & repeatability timing compensated for output relay delay. Flexible functionality, various optional reset functions and alarm indication. Suitable for use in protection & control schemes where precision time delays are required.

		Page
MS2T105	Multi range digital setting time delay relay	34



Frequency

Frequency monitoring relays with four stages of load shedding. Each stage can be established for the detection of very fast frequency loss due to disconnection from the main grid.

MS2H34-S	Definite time frequency	Page 36
----------	-------------------------	------------



High impedance differential

High speed differential protection for various items of power system plant including generators, busbar, motors & the individual windings of power transformers and for restricted earth fault applications.

MS2V68	Busbar CT supervision & shorting	Page 38
MS2V73	High impedance differential	39
MS2V75	Metrosil / resistor module	40



Voltage regulation

Voltage monitoring relays, suitable where high accuracy and reliable, maintenance free operation is essential. Applicable for a wide range of protection & control applications.

MS2V164-S	Voltage regulating & tap change control	Page 42
MS1M122	Transformer parallel control system	43
MS4D200	TPI display module	44



Auto reclose & sync check

Automatic reclose of the circuit breaker, after the fault clears, provides improved service continuity & system stability. An auto reclose relay provides for single or double shot automatic reclosing of circuit breakers, following interruption of supply due to a fault in the system.

MS1B230	Single or double shot auto reclose relay	Page 46
MS2SY212-S	Synchronism check	47



Current

Current monitoring relays provide high speed overcurrent protection. AC or DC current sensing relays designed for high or low voltage power systems where they can be used in a large number of overcurrent applications.

MS2C74	Instantaneous current relay	Page 50
MS2C00	Self-powered overcurrent relay	51



Housings & dimensions

Empty diode box for custom applications and dimensions of all available housings.

MS4O203	Empty housing	Page 54
MS2M28-S	Dimensions MS2M28-S	55
MS4M28-S	Dimensions MS4M28-S	56
MS4M56-S	Dimensions MS4M56-S	57



Standards & approvals

Standards & approvals



are designed and manufactured with utmost care for reability and durability. The relays are in compliance with the leading international standards.

- EN 60255 Relay design, specifications and environmental conditions. Electrical relays.
- IEC 60068 Environmental testing
- IEC 60529 International standard describes the protection class (IP code).
- IEC 61850 International standard of communications for substations.

Contact descriptions

	International	USA	ANSI
Normally open contact	N/O	SPST-NO	form A
Normally closed contact	N/C	SPST-NC	form B
1 changeover contact	1 C/O	SPDT	form C
2 changeover contacts	2 C/O	DPDT	form C
3 changeover contacts	3 C/O	3PDT	form C
4 changeover contacts	4 C/O	4PDT	form C
1 double break / double make contact	1 C/O DB/DM	SPDT (DB/DM)	form Z
4 double break / double make contact	4 C/O DB/DM	4PDT (DB/DM)	form Z



Auxiliary, trip & supervision

The effect of a fault on a power system is dependent on the speed with which the fault can be detected and isolated. Modern protection schemes incorporate ever increasing functionality through the application of digital techniques to protection relay technology.

The requirement for highly reliable tripping and control relay elements does however remain and often constitutes a significant cost and space requirement when considering protection panel designs.

The Actus system fulfills this need by providing a compact, flexible and high performance solution, while at the same time reducing the cost and lead times normally associated with this class of device.

Application of the Actus multi-contact high-speed trip relays ensures fast operation of less than 8 ms. The unique patented design and topology ensures minimal contact bounce.

- Ultimate protection of critical applications
- Numerous options
- High reliability

Auxiliary, trip & supervision

MSTR

High speed tripping relay



The MSTR relays represents a new generation of high speed electro-mechanical tripping relays for power utility protection and control applications.

Application of the MSTR multi-contact high speed trip relays ensures fast operation of less than 8 ms and ensures minimal contact bounce.

- Low burden auxiliary relay
- Self-reset, hand reset or hand/electrical reset
- Electromechanical flag indication
- High reliable double action contacts
- High operate speed and low bounce
- 5, 2x 5 or 12 heavy duty contacts
- Optional gold plated contacts suitable for low currents
- Optional custom labeling
- Optional relay operate LED
- Optional trip counter
- Optional electrical reset isolation switch
- Wide range of operating voltages

Options

- Operating voltage
- Contact configuration
- Contact operation
- Flag indicators
- Operation counter
- Gold plated contacts
- Coil operating LED
- Electrical reset isolation switch
- Custom labeling

Technical data

Maximum make current	30 A
Maximum continuous current	8 A
Maximum switching voltage	660 VAC/VDC
Contact specification	5, 2x 5 or 12 contacts, depending on model
Operating time	≤ 35 ms
Auxiliary supply voltage	Wide range, refer to datasheet
Operating range	DC: 80 %...110 % Un AC: 70 %...120 % Un

Environmental data

Dimensions	MS2M28-S
Mounting	19" rack frame or flush
Operating temperature	-10 °C...+55 °C
Humidity	93 % RH non condensing, 40 °C

Detailed information and datasheets are available on www.morssmitt.com

MSAR

High performance auxiliary relay



The MSAR relays provides high performance and reliability while reducing production and supply lead times.

Application of the MSAR multi-contact auxiliary relays ensures reliable operation of up to 12 output contacts in a compact size 2 draw out case. The unique patented design and topology ensures minimal contact bounce.

- Low burden auxiliary relay
- Self-reset, hand reset or hand/electrical reset
- Electromechanical flag indication
- High reliable double action contacts
- High operate speed and low bounce
- 5, 2x 5 or 12 heavy duty contacts
- Optional gold plated contacts suitable for low currents
- Optional custom labeling
- Optional relay operate LED
- Optional trip counter
- Optional electrical reset isolation switch
- Wide range of operating voltages

Options

- Operating voltage
- Contact configuration
- Contact operation
- Flag indicators
- Operation counter
- Gold plated contacts
- Coil operating LED
- Electrical reset isolation switch
- Custom labeling

Technical data

Maximum make current	30 A
Maximum continuous current	8 A
Maximum switching voltage	660 VAC/VDC
Contact specification	5, 2x 5 or 12 contacts, depending on model
Operating time	≤ 35 ms
Auxiliary supply voltage	Wide range, refer to datasheet
Operating range	DC: 80 %...110 % Un AC: 70 %...120 % Un

Environmental data

Dimensions	MS2M28-S
Mounting	19" rack frame or flush
Operating temperature	-10 °C...+55 °C
Humidity	93 % RH non condensing, 40 °C

Detailed information and datasheets are available on www.morssmitt.com

Auxiliary, trip & supervision

MSXR

Supervision relay



The MSXR low burden electro-mechanical supervision relays for application on high security tripping and auxiliary supply circuits.

The fast pick-up time of ≤ 8 ms ensures total intertrip time is kept to a minimum.

- Selectable low or high burden
- Electromechanical flag indication
- 5 kV isolation for application as intertrip send relay
- Fast pick-up time, ≤ 8 ms
- High reliable double action contacts
- High operate speed and low bounce
- Configurable operate period
- 5 heavy duty contacts
- Wide range of operating voltages
- Optional gold plated contacts
- Optional custom labeling
- Optional coil operation LED
- Wide range of operation voltages

Options

- Operating voltage
- Contact configuration
- Contact operation
- Flag indicators
- Gold plated contacts
- Coil operating LED
- Custom labeling

Technical data

Maximum make current	30 A
Maximum continuous current	8 A
Maximum switching voltage	660 VAC/VDC
Contact specification	5 contacts, to be specified
Operating time	≤ 8 ms
Auxiliary supply voltage	Wide range, refer to datasheet
Operating range	DC: 50 %...120 % Un

Environmental data

Dimensions	MS2M28-S
Mounting	19" rack frame or flush
Operating temperature	-10 °C...+55 °C
Humidity	93 % RH non condensing, 40 °C

Detailed information and datasheets are available on www.morssmitt.com

Auxiliary, trip & supervision

MSPR

Pilot wire intertrip relay



The MSPR-S intertrip SEND relay is used to interface trip circuit contacts, or other conventional protection relay contacts to the pilot wire with suitable electrical isolation for the feeder voltage level.

The fast pick-up time of < 8 ms ensures total intertrip time is kept to a minimum.

- User selectable low or high burden
- Self-reset, hand reset or hand/electrical reset
- Electrical reset interlock
- Electromechanical flag indication
- High reliable double action contacts
- High operate speed and low bounce
- 5 or 12 heavy duty contacts
- Optional gold plated contacts suitable for low currents
- Optional custom labeling
- Optional relay operate LED
- Optional trip counter
- Optional electrical reset isolation switch
- Wide range of operation voltages

Options

- Operating voltage
- Contact configuration
- Contact operation
- Flag indicators
- Operation counter
- Gold plated contacts
- Coil operating LED
- Electrical reset isolation switch
- Custom labeling

Technical data

Maximum make current	30 A
Maximum continuous current	8 A
Maximum switching voltage	660 VAC/VDC
Contact specification	5 or 12 contacts, depending on model
Operating time	≤ 8 ms
Auxiliary supply voltage	Wide range, refer to datasheet
Operating range	DC: 50 %...120 % Un

Environmental data

Dimensions	MS2M28-S
Mounting	19" rack frame or flush
Operating temperature	-10 °C...+55 °C
Humidity	93 % RH non condensing, 40 °C

Detailed information and datasheets are available on www.morssmitt.com

Auxiliary, trip & supervision

MS1X50

CB trip & close module



Two 22 mm heavy duty push buttons for the manual control & indication of CB status. The panel or rack mount configuration allows the compact MS1X50 to be located on the protection panel adjacent to the feeder protection relay.

An optional locking cover is available to preclude unauthorised operation of the trip & close buttons during maintenance activities for example.

- Large size push buttons
- High visibility CB status LEDs
- Optional CB spring charge status LED
- Standard panel cover
- Optional locking cover
- Heavy duty output contacts
- Optional custom engraving
- Optional lamp test button & output contact
- Optional integrated control circuit steering diodes
- Wide range of operating voltage

Options

- System voltage
- Button & LED colours
- Custom engraved description
- Steering diodes
- Lockable cover
- Spring charge LED status
- Lamp test button

Technical data

Maximum make current	40 A
Maximum continuous current	10 A
Maximum switching voltage	250 VDC
Contact specification	Trip button 2 N/O contacts Close button 2 N/O contacts Lamp test button 2 N/O contacts
Auxiliary supply voltage	Wide range, refer to datasheet

Environmental data

Dimensions	MS2M28-S
Mounting	19" rack frame or flush
Operating temperature	-5 °C...+55 °C
Humidity	95 % RH non condensing, 40 °C

Detailed information and datasheets are available on www.morssmitt.com



Arc fault protection

Arc fault protection for the fast clearance of arcing faults on BUS bars & within metal clad switchgear & associated cable boxes. The arc is detected using an optical sensor & the signal input to a protection device which also monitors the load current on the system.

A trip signal can be achieved in less than 10 ms using arc detection only or within 15 ms when using overcurrent check. This is considerably faster than a traditional IDMT overcurrent relay and provides additional protection from the onset of arcing faults with relatively low fault currents.

- Protection for fast clearance of arcing faults
- Reliable protection with ≤ 10 ms arc detection
- Faster than traditional IDMT protection

Arc fault protection

MS1S20

Arc fault monitor



The arc is detected using an optical sensor & the signal input to a protection device which also monitors the load current on the system. When an arc fault start current is coincident with a signal from the optical sensor a trip command is output.

A trip signal can be achieved within 10 ms which can be considerably faster than that provided by a traditional IDMT overcurrent relay. This is because the onset of an arcing fault can occur at relatively low fault currents.

- Compact, economic design
- Simple panel mounting for retrofit applications
- One, two or three independent arc sensor inputs
- Two high speed tripping arc sense output contacts
- Push button reset
- Integrated self-supervision
- Fail alarm contact
- Supply 20...60 VDC or 36...150 VDC

Options

- Auxiliary supply range
- Mounting
- Number of sensor inputs

Dimensions



Technical data

Maximum make current	30 A
Maximum continuous current	5 A
Maximum switching voltage	660 VAC/DC
Contact specification	2 N/O arc fault trip contacts 1 N/C fail alarm contact
Operating time	≤ 10 ms
Auxiliary supply voltage	20...60 VDC or 36...150 VDC
Environmental data	
Mounting	Panel or surface (depending on option)
Operating temperature	-5 °C...+55 °C
Humidity	95 % RH non condensing, 40 °C

Detailed information and datasheets are available on www.morssmitt.com

Arc fault protection

MS1S23

Arc fault interface module



The arc fault interface module is designed to connect one or two optical arc fault sensors to a protection relay status input.

- Compact, simple, rugged and economic design
- Simple wiring and 35 mm rail mounting
- Interface for one or two MS1S30 arc fault sensors
- High speed arc fault tripping output to interface with protection relay status inputs
- Apply to initiate IEC 61850 GOOSE messaging of arc fault events
- Continuous arc fault sensor supervision
- Arc fault pick up and supervision healthy indication
- Wide range of operating voltages

Options

- Optical sensor interface
- Auxiliary supply

Dimensions

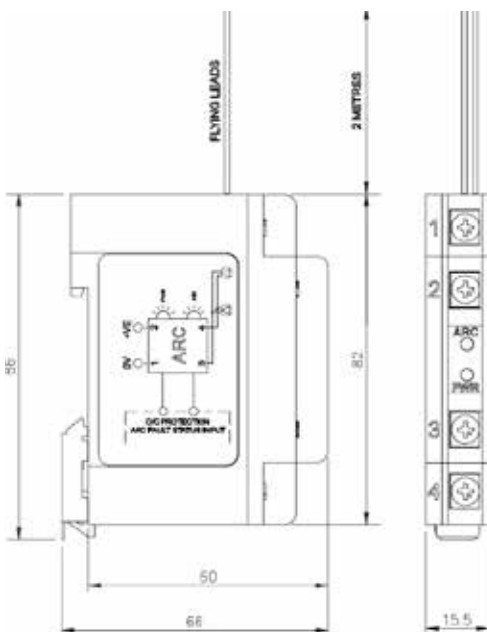

Technical data

Maximum make current	15 mA
Maximum continuous current	5 mA
Maximum switching voltage	125 % of U_n
Contact specification	Arc detection output 1 N/O Sensor & module fail output 1 N/O
Operating time	Arc detection ≤ 2 ms Overcurrent check 15 ms
Auxiliary supply voltage	Wide range, refer to datasheet
Operating range	DC 80 %...120 % U_n

Environmental data

Mounting	35 mm rail
Operating temperature	-10 °C...+55 °C
Humidity	93 % RH non condensing, 40 °C

Detailed information and datasheets are available on www.morssmitt.com

Arc fault protection

MS1S24

Arc fault monitoring system



The MS1S24 is an arc fault monitoring system, capable of being employed in the most challenging applications with reduced engineering overhead. With the flexibility of the IEC 61850 standard arc tripping with current checking or arc tripping with operational interlocks are able to be implemented with ease.

- Up to 16 arc fault sensors
- Up to 16 independent arc fault SARC logic nodes
- Arc fault signaling via Ethernet IEC 61850 GOOSE messaging
- 10 base-T / 100 Base-TX port
- Optional 100 Base-FX port
- Trip indication LED for each arc fault sensor
- Continuous arc sensor supervision with sensor fail LED for each zone
- Nonvolatile memory ensures last recorded alarm states are restored on power up
- High speed arc fault tripping duty output contacts < 10 ms
- System configuration via web browser
- Wide range status input to block arc fault tripping
- Front panel reset button and status input
- Self-supervision watchdog with healthy LED and alarm contact
- Wide range auxiliary supply

Options

- Auxiliary supply range
- Ethernet connection

Dimensions

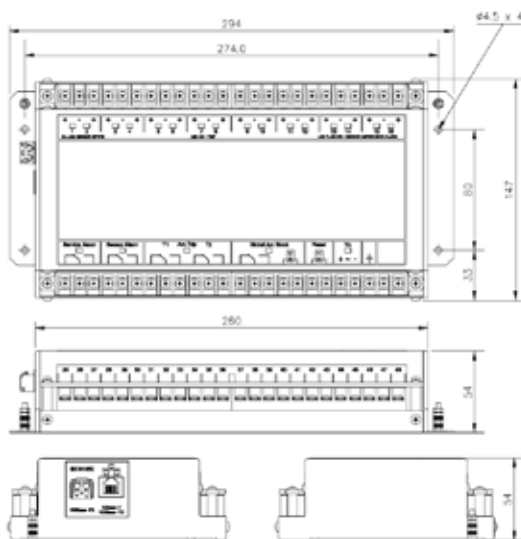

Technical data

Maximum make current	30 A
Maximum continuous current	5 A
Maximum switching voltage	660 VAC/ DC
Contact specification	2 C/O tripping contacts 1 C/O sensor alarm contact 1 C/O system fail alarm contact
Operating time	≤ 10 ms
Auxiliary supply voltage	Wide range, refer to datasheet

Environmental data

Mounting	Surface
Operating temperature	-10 °C...+55 °C
Humidity	93 % RH non condensing, 40 °C

Detailed information and datasheets are available on www.morssmitt.com

MS1S25

Arc fault monitor



Arc fault monitor with up to 8 arc fault sensors connections in 4 independent tripping zones.

When an arc fault start current is coincident with a signal from the optical sensor a trip command is output. A trip signal can be achieved within 10 ms.

- 4 independent arc fault tripping zones
- 1 or 2 arc fault sensors per zone allowing up to 8 arc fault sensors to be connected per MS1S25 module
- Trip indication LED for each arc fault monitoring zone
- Non-volatile memory ensures last recorded alarm states are restored on power up
- 5 high speed arc fault tripping output contacts (set for latching or self-reset)
- Zone segregated or common tripping output configuration
- Continuous arc sensor supervision with sensor fail LED for each tripping zone
- Wide range status input to block arc fault monitoring
- Front panel reset button & status input
- Self-supervision watchdog with healthy LED & alarm contact
- Built-in test sequence
- Wide range auxiliary supply

Options

- Auxiliary supply range
- Custom engraved text
- Zone 1-4 sensor inputs
- Zone 1-4 second sensor
- Output contact function
- Output contact grouping
- Arc fault initiate input function
- Status input AC rejection

Technical data

Maximum make current	30 A
Maximum continuous current	5 A
Maximum switching voltage	660 VAC/ DC
Contact specification	8 contacts (2 N/O per tripping zone) 1 N/O common tripping contact 1 C/O fail alarm contact
Operating time	≤ 10 ms
Reset time	2 s
Auxiliary supply voltage	Wide range, refer to datasheet

Environmental data

Housing	MS2M28-S
Mounting	19" rack frame or flush
Operating temperature	-5 °C...+55 °C
Humidity	95 % RH non condensing, 40 °C

Detailed information and datasheets are available on www.morssmitt.com

Arc fault protection

MS1S30

Optical arc fault sensor



The MS1S30 is an optical sensor that responds to the flash of light emitted during the incidence of an arcing fault.

Onset of the light flash & detection by the MS1S30 occurs in a few ms. Each arc fault sensor consists of one or two silicon PIN photo diode light detectors mounted on a circuit board together with the associated detection circuit. The detector monitors a wide space angle.

Sensitivity of the arc sensor has been set to a low level to reduce the possibility of mal operation under high ambient lighting conditions.

- 1 or 2 optical detectors
- High speed arc detection
- Compact rugged design
- Heavy duty 6 m termination cable
- Optional 20 m & screened cables
- Simple flush panel mounting outside or inside switchgear compartment
- Integrated sensor circuit supervision
- Very low sensitivity to ambient light levels to avoid nuisance tripping even in direct sunlight
- Sealed module for harsh environments
- Optional metal reinforced mounting shield

Options

- Single or dual detector
- Flush mount reinforcing plate
- 6 or 20 m cable

Dimensions

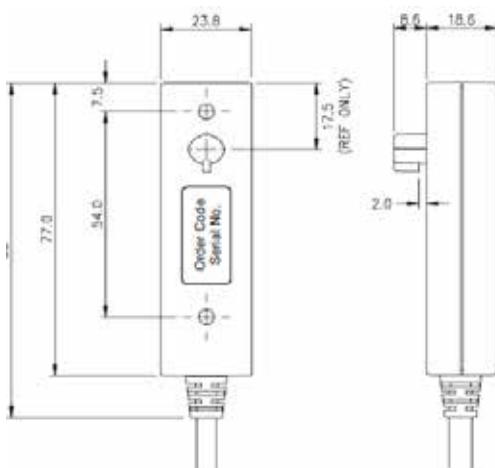

Technical data

Minimum arc duration	1.25 ms
Power consumption	< 2.5 mA
Auxiliary supply voltage	12 VDC

Environmental data

Mounting	19" rack frame of flush
Operating temperature	-5 °C...+55 °C
Humidity	93 % RH non condensing, 40 °C

Detailed information and datasheets are available on www.morssmitt.com



SERVING
SAFETY



Testblock and plug system

Test links are an important accessory for protection, metering and control panels. They enable test technicians to quickly and safely isolate protection relays so that test signals may be injected and system performance verified.

The test link plugs are designed as a general-purpose isolation and test signal injection point. 'Finger safe' sockets are employed to improve operator safety and to suit 4mm shrouded 'finger safe' type banana plugs. Equipment under test need only be removed for servicing if problems are detected.

- Reduction in down time of the equipment under test
- Testing does not cause disturbance to wiring, terminals or equipment settings
- Existing auxiliary supply to the equipment under test may be isolated

Testblock & plug system

MS4M400



Testblock

The MS4M400 testblock has 14 test groups that may be specified at time of order to provide automatic CT shorting and sequential circuit to suit specific protection schemes. The main advantage of this approach is the improved level of safety and security afforded to the CT circuits. This is because the CT shorting function takes place within the MS4M400 test block irrespective of the CT circuit position.

In many test block systems the CT shorting is only accomplished when the test plug is inserted which leaves open the possibility of a CT circuit becoming open circuit due to the CT shorting links being omitted or in the wrong position. This potential problem is negated in the MS4M400 and allows a single model MS4M420 test plug to be employed for all MS4M400 test block configurations.

- 14 independent test groups may be specified with any combination of circuit types
- Automatic shorting of CT circuits completed in the test block - No test links or operator intervention required
- Isolation plug provides sequential circuit isolation timing in 3 stages
- Clear and concise front panel circuit identification
- Side label instructions on test plug for changing from normal service to test condition
- High current / voltage rating

Options

- 14 test circuits, specified in any configuration

Technical data

Maximum make current	400 A CT circuit and terminals 200 A other circuits
Maximum continuous current	20 A CT circuits and terminals 10 A other circuits
Maximum switching voltage	300 VAC/ DC

Environmental data

Housing	MS2M28-S
Mounting	19" rack fram of flush
Operating temperature	-10 °C...+55 °C
Humidity	93 % RH non condensing, 40 °C

Detailed information and datasheets are available on www.morssmitt.com

Testblock & plug system

MSM420

Test plug



The MS4M420 test plug has been designed as a general-purpose test signal injection point. Finger safe 4 mm diameter sockets are employed so that shrouded or common banana plugs may be used to short CT inputs & connect test equipment.

By removing an MS4M400 test block and placing the MS4M420 enables test technicians to quickly & safely isolate protection relays so that test signals may be injected & system performance verified.

- Finger safe test sockets
- Suitable for standard or shrouded 4 mm banana plugs
- Large plug handles
- Optional automatic CT shorting function
- Optional automatic DC auxiliary isolation
- High current / voltage rating
- Compact & economic design
- 3x 75 mm + 3x 180 mm 'finger safe' shrouded shorting leads included

Technical data

Maximum make current	400 A CT circuit and terminals 200 A other circuits
Maximum continuous current	20 A CT circuits and terminals 10 A other circuits
Maximum switching voltage	300 VAC/ DC

Environmental data

Housing	MS2M28-S
Mounting	19" rack fram of flush
Operating temperature	-10 °C...+55 °C
Humidity	93 % RH non condensing, 40 °C

Detailed information and datasheets are available on www.morssmitt.com

Testblock & plug system

MS2MRLB-S



Options

- Automatic CT shorting links

Dimensions

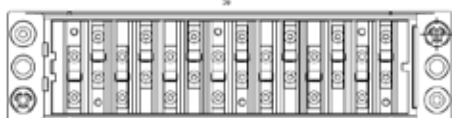
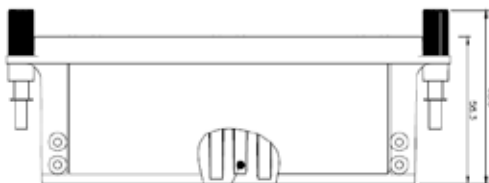
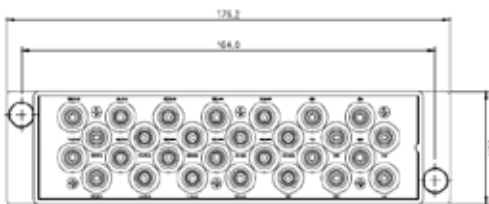

Multi-finger test plug

The MS2MRLB-S multi-finger test plug is an evolution of the popular test plug employed with Reyrolle & Areva test blocks. The primary difference is the incorporation of 'finger safe' test sockets which allow the use of shrouded 4 mm banana plugs.

Insertion of the MS2MRLB-S test plug into the test block first connects and open circuits each pair of contacts which connected to the rear terminals. The MS2MRLB-S test plug locates securely into the test block and can be retained by two knurled screws.

The 28 'finger safe' test sockets on the MS2MRLB-S are divided into 2 groups of 14:

- 14 even numbered equipment side BLACK test sockets
- 14 odd numbered live side YELLOW test sockets

Each of these 28 test sockets accepts a 4 mm shrouded or standard type plug.

- Colour coded 'finger safe' test sockets suit standard or shrouded type 4 mm banana plugs
- Compatible with industry standard 14 circuit test blocks e.g. Siemens 2RMLG / 7XG22 & Areva MMLG
- Clear & concise front panel circuit identification
- Test block obviates the need to disturb protective system wiring for testing purposes
- Available with internal automatic CT shorting links
- High current / voltage rating

Technical data

Maximum make current	400 A CT circuit and terminals
Maximum continuous current	20 A CT circuits and terminals
Maximum switching voltage	300 VAC/ DC

Environmental data

Mounting	19" rack fram of flush
Operating temperature	-5 °C...+55 °C
Humidity	93 % RH non condensing, 40 °C

Detailed information and datasheets are available on www.morssmitt.com

MS4MLEADS

Accessories for test plugs

There are 2 types of test leads available for the Mors Smitt test plug systems.

The shrouded 'finger safe' test leads are available to short CT inputs & connect test equipment to the MS4M420 and MS2RMLB-S test plugs. The dual plugs can be linked by stacking the plugs.



- 4 mm 'finger safe' banana plugs
- Single or dual plugs available
- Length 75 mm or 180 mm

Specifications

Wire dimensions	2.5 mm ²
Wire type	Multi-strand wire
Material	Yellow PVC insulations
Length	75 or 180 mm (depending on model)

Detailed information and datasheets are available on www.morssmitt.com

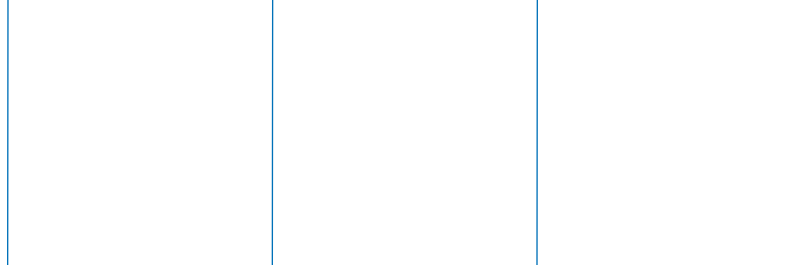



SERVING
SAFETY



Alarm panels

Alarm panels are an effective choice for the annunciation of alarms & operating events. The alarm points indicate an alarm situation of an specific application. Alarm groups can be configured for instantaneous or time delayed operation. Multiple alarm panels can be used for high density alarm applications.

The following examples represent typical alarm panel installations:

- Transformer alarm panel
- Quantity high / low
- Timing status
- Intrusion / security status
- Device operational status
- Breaker / switch position
- Protection relay status
- Trip & alarm contact multiplication

Alarm panels

MS1A54



Alarm panels

The MS1A54 is a flexible & cost effective choice for the annunciation of alarms & operating events. The MS1A54 can be scaled for 4, 8 or 16 alarm points to indicate as few or as many points as needed for a specific application.

Multiple alarm panels can be used for high density alarm applications. The wide voltage operating range, heavy duty output contacts & rugged draw out case construction makes the protection class MS1A54 suitable for various substation applications.

- 4, 8 or 16 alarm panel versions
- Rack or panel mount draw out case design
- LED-indication for each alarm point with custom label text
- Nonvolatile memory ensures retention of alarm states
- Wide range status input to initiate each alarm point
- Selectable time delayed or instantaneous alarm function
- Up to 6 repeat output contacts for each alarm point
- Common alarm output contact
- Front panel acknowledge button & status input
- Front panel reset button & status input
- Self-supervision watchdog with healthy LED & alarm contact
- Built in test sequence
- Wide range auxiliary supply

Options

- Alarm points
- Auxiliary supply range
- Custom engraved text
- Status input time delay

Technical data

Maximum make current	30 A
Maximum continuous current	8 A
Maximum switching voltage	660 VAC/ DC
Contact specification	5, 12 or 2x 5 contacts, depending on model
Operating time	≤ 35 ms
Auxiliary supply voltage	Wide range, refer to datasheet
Operating range	DC: 80 %...110 % U _n AC: 70 %...120 % U _n

Environmental data

Housing	MS2M28-S
Mounting	19" rack frame or flush
Operating temperature	-5 °C...+55 °C
Humidity	95 % RH non condensing, 40 °C

Detailed information and datasheets are available on www.morssmitt.com



SERVING
SAFETY

Phase monitoring

Phase monitoring relays are suitable for the detection of excessive negative sequence voltage resulting from phase failure, phase unbalance or reversed phase sequence.

Suitable for the protection of:

- Protection of rotating plants
- Voltage change over schemes

Phase monitoring

MS2P48

Potential selecting relay

The MS2P48 relay is designed to automatically change over from the primary supply to the secondary supply if any phase of the primary supply has faulted. A front panel LED will indicate the faulted phase thus allowing easy recognition of the fault. Each of the incoming phases for both primary and secondary supplies have LED indicators to indicate healthy supplies.

The outgoing phases have the same indicators. The LEDs will extinguish for the following conditions excessive negative sequence voltage resulting from phase failure, phase unbalance and reversed phase sequence. The MS2P48 output relay is normally energised and drops out when phase angle unbalance is greater than the pre-set, under voltage or reverse phase sequence.

- Detects phase angle imbalance
- Detects reverse phase sequence
- Detects supply undervoltage
- Unaffected by frequency variations of ± 5 Hz
- Adjustable 5-15 % out of balance setting
- Failsafe operation (contact normally picked up)
- Filter rejects harmonics & control tones
- LED indicators to show healthy incoming and outgoing supplies
- No auxiliary voltage required



Options

- Sensing supply frequency
- Time delay
- Magnetic blowouts

Technical data

Maximum make current	30 A
Maximum continuous current	12 A
Maximum switching voltage	660 VAC/VDC
Contact specification	4 C/O voltage selection contacts 1 C/O alarm contact
Operating time	Various, refer to datasheet
Sensing supply voltage	110 VAC, 50 or 60 Hz (depending on model)

Environmental data

Dimensions	MS4M28-S
Mounting	19" rack frame or flush
Operating temperature	-5 °C...+55 °C
Humidity	93 % RH non condensing, 40 °C

Detailed information and datasheets are available on www.morssmitt.com

Phase monitoring

MS2P49

3-phase voltage monitoring relay



The MS2P49 relay is a phase failure relay suitable for 3-phase supplies. The relay is designed to provide protection for rotating equipment from the damaging effects of excessive negative sequence voltage resulting from phase failure, phase unbalance and reversed phase sequence.

The MS2P49 output relay is normally energised and drops out when phase angle unbalance is greater than the pre-set. The relay will also drop out for undervoltage or reverse phase sequence conditions.

- Detects phase angle imbalance
- Detects reverse phase sequence
- Detects supply undervoltage
- Unaffected by frequency variations of ± 5 Hz
- Adjustable 5-15 % out of balance setting
- Range of detection voltages & frequencies available
- Fail safe operation (Contact normally picked up)
- Filter rejects harmonics & control tones
- No auxiliary voltage required

Options

- Sensing supply frequency
- Time delay
- Output contacts

Technical data

Maximum make current	30 A
Maximum continuous current	12 A
Maximum switching voltage	660 VAC/VDC
Contact specification	4 C/O voltage selection contacts (optional) 2 C/O contacts
Operating time	Various, refer to datasheet
Sensing supply voltage	Wide range, refer to datasheet

Environmental data

Dimensions	MS2M28-S
Mounting	19" rack frame or flush
Operating temperature	-5 °C...+55 °C
Humidity	93 % RH non condensing, 40 °C

Detailed information and datasheets are available on www.morssmitt.com

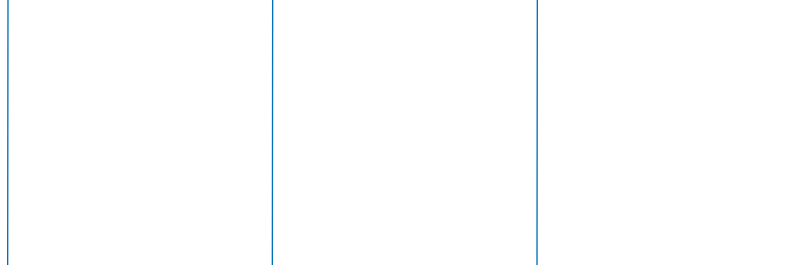



SERVING
SAFETY

Timer relays

Timer relays are particularly suitable for use in protection & control schemes where precision time delays are required for example in circuit breaker failure protection.

Timer relays

MS2T105

Multi range digital setting time relay



The MS2T105 time delay relay is particularly suitable for use in protection & control schemes where precision time delays are required. A typical use is in providing a definite time delay in circuit breaker failure protection.

For example: The transformer multi-trip relays energises the MS2T105 timer & if the circuit breaker (CB) fails to clear the fault within the pre-set (0.6 s) the timer times out & operates a multi-trip relay. This in turn trips all CB's on the section of the busbar connected to the CB which has failed to trip.

- 4 time ranges: 0...0.99 s, 0...9.9 s, 0...99 s, 0...990 s
- High accuracy & repeatability
- Time settings easily selected by digital thumb wheel switches
- Selectable delay operate or delay relays
- Optional reset functions: Instantaneous, definite time, count down
- 4 C/O output contacts
- Fail alarm contact
- Timing in progress LED
- Non-volatile trip indication
- Multi voltage timer initiate & flag reset inputs
- Wide range auxiliary supply

Options

- Auxiliary supply range
- Timing reset function
- Trip flag
- Status input operation
- Timer initiate input
- Time delay function
- Output relay function
- Time range multiplier

Technical data

Maximum make current	30 A
Maximum continuous current	5 A
Maximum switching voltage	300 VAC/VDC
Contact specification	4 C/O contacts 1 C/O fail alarm contact
Operating time	6 ms
Adjustable time delay	0...0.99 s, 0...9.9 s, 0...99 s, 0...990 s
Sensing supply voltage	Wide range, refer to datasheet

Environmental data

Dimensions	MS2M28-S
Mounting	19" rack frame or flush
Operating temperature	- 10 °C...+55 °C
Humidity	95 % RH non condensing, 40 °C

Detailed information and datasheets are available on www.morssmitt.com



SERVING
SAFETY

Frequency

Reduction in system frequency is an early indicator of impending system voltage collapse. This can lead to plant & equipment damage if not taken off line or the frequency / voltage level restored.

Frequency monitoring relays can be set for under or over frequency operation & have an independent time delay driving an output relay. An undervoltage lockout is used to disable the four frequency outputs when the voltage falls below a preset level.

Frequency

MS2H34-S

Definite time frequency relay with ROCOF



The MS2H34 relay is a frequency monitoring relay with four stages of adjustable frequency pick up & drop out points. Each frequency set point can be set for under or over frequency operation & has an independent time delay driving an output relay.

An undervoltage lockout is used to disable the four frequency outputs when the voltage falls below a preset level. A single status input is used to enable the four frequency sensing stages.

- 41 to 59 Hz PU setting range
- Rate of frequency change (df/dt) detection algorithm
- Adjustable pick up, drop out & reset time delay
- Four independent setting stages & output trip contact
- Timing & trip indication LEDs
- Relay enable input
- CPU watchdog
- Undervoltage blocking function
- Overvoltage & undervoltage alarm outputs
- Front panel USB PC programming port
- Optical isolated RS485 / RS232 network port with MODBUS RTU

Options

- Auxiliary supply range
- Relay initiate input
- Remote flag reset input
- Rear communications port
- Application software

Technical data

Maximum make current	30 A
Maximum continuous current	5 A
Maximum switching voltage	330 VAC/VDC
Contact specification	1 C/O stage 1 contact 1 C/O stage 2 contact 1 C/O stage 3 contact 1 C/O stage 4 contact 1 C/O undervoltage blocking contact 1 N/O overvoltage stage contact 1 N/O undervoltage stage contact
Sensing supply voltage	20...70 VDC or 40...275 VAC / 300 VDC

Environmental data

Dimensions	MS4M56-S
Mounting	19" rack frame or flush
Operating temperature	-5 °C...+55 °C
Humidity	95 % RH non condensing, 40 °C

Detailed information and datasheets are available on www.morssmitt.com



SERVING
SAFETY

High impedance differential protection

High speed differential protection for various items of power system plant including generators, bus bars, motors & the individual windings of power transformers and for restricted earth fault applications.

High impedance differential protection

MS2V68

Busbar CT supervision and shorting



The MS2V68 is a 3-phase monitoring device designed to provide continuous supervision of the bus wires in high impedance type bus wire protection schemes.

The relay will detect open circuited bus wires as well as open circuited main current transformers. The relay provides 3 latching N/O alarm output contacts to signal faults. 3 additional N/O latching output contacts are provided for an integral bus wire CT shorting facility.

- Low AC burden
- No external resistors required
- 3 latching N/O (hand reset), alarm contacts
- 3 latching N/O (hand reset), bus wire shorting contacts
- Hand reset flag
- 40...300 VDC auxiliary supply / 40...275 VAC auxiliary supply
- Optional 20...70 VDC supply
- Power supply fail relay drops out if the auxiliary supply fails
- 3 s fixed time delay

Options

- Auxiliary supply range

Technical data

Maximum make current	30 A
Maximum continuous current	12 A
Maximum switching voltage	660 VAC/VDC
Contact specification	3 N/O bus wire contacts 3 N/O alarm contacts
Operating time	3 s fixed time delay
Auxiliary supply voltage	20...70 VDC or 40...300 VDC / 40...275 VAC

Environmental data

Dimensions	MS4M28
Mounting	19" rack frame or flush
Operating temperature	-5 °C...+55 °C
Humidity	93 % RH non condensing, 40 °C

Detailed information and datasheets are available on www.morssmitt.com

High impedance differential protection



MS2V73

High impedance differential protection



The MS2V73 relay provides high speed differential protection for various items of power system plant including generators, busbar, motors, individual windings of power transformers and restricted earth fault applications. Each relay can be set from 25 to 325 VAC in 50 V steps.

A capacitor is connected in series with the operating coil to make the relay insensitive to the DC component of fault current. The setting can thus be calculated in terms of RMS AC quantities without regard for the degree of offsets produced by the point on wave at which the fault occurs.

An inductor connected in series with the capacitor forms a resonant circuit tuned to the relays rated frequency.

- High speed operation
- High sensitivity & stability
- Wide range of settings
- Use 3 units for 3-phase protection
- 50 Hz or 60 Hz versions available
- Insensitive to DC
- Hand or electrical reset flag indicator
- Rugged attracted armature sensing elements
- Wide range of operating voltages

Options

- Setting range
- Rated frequency
- Mechanical flag trip indication
- Magnetic flag trip indication

Technical data

Maximum make current	30 A
Maximum continuous current	12 A
Maximum switching voltage	660 VAC/VDC
Contact specification	2 N/O contacts
Operating time	≤ 20 ms at 4 times V_s
Auxiliary supply voltage	Wide range, refer to datasheet

Environmental data

Dimensions	MS2M28-S
Mounting	19" rack frame or flush
Operating temperature	-5 °C...+55 °C
Humidity	95 % RH non condensing, 40 °C

Detailed information and datasheets are available on www.morssmitt.com

High impedance differential protection

MS2V75

Metrosil / resistor module

The MS2V75 module provides a compact, simple & cost effective means of fitting a prewired 3-phase metrosil & resistor combination into protection panels employing high impedance differential schemes.

The separate 3-phase metrosil module is installed from the rear of the cubicle & latched onto the self-aligning rails on the front mounting panel. Retention screws are provided to lock the Metrosil module in place. The rear terminal door may be swung open to access the stabilizing resistors (where fitted) to allow adjustment.

The completed installation is compact while providing safety isolation, the desired level of ventilation for the stabilizing resistors and a means of simple adjustment.

- Compact & rugged construction
- Fully insulated module
- High energy absorption rating
- Pre-wired with heavy duty stud or screw terminals
- Specify 3 or 6 inch metrosil
- Adjustable stabilizing resistors
- Excellent mechanical & thermal performance
- Suitable for high impedance differential BUS protection schemes
- Wide range of operating voltages



Options

- Metrosil size
- Stabilizing resistor value
- Mounting hardware
- Stabilizing resistor power rating
- Single or three phase
- Internal or external shunt wiring

Dimensions

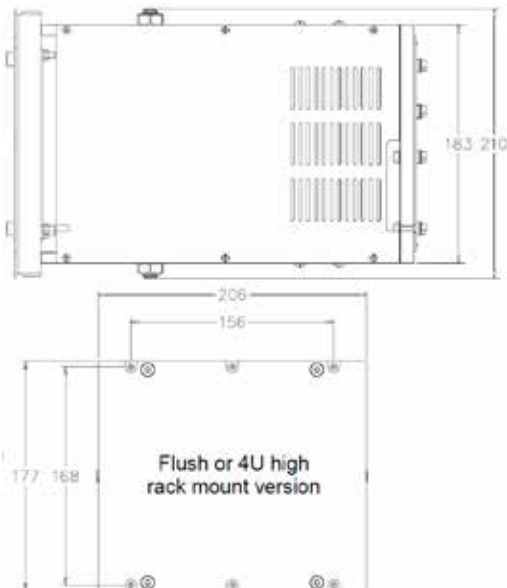

Technical data

Current	300 A or 600 A
Stabilising resistors	100 W or 200 W
Resistance	250, 500 or 1000 Ω

Environmental data

Mounting	Rack, panel or surface
Operating temperature	-10°C...+55 °C
Humidity	93 % RH non condensing, 40 °C

Detailed information and datasheets are available on www.morssmitt.com



SERVING
SAFETY

Voltage regulation

Voltage monitoring relays, suitable where high accuracy and reliable, maintenance free operation is essential. Applicable for a wide range of protection & control applications.

Voltage regulation

MS2V164-S

Voltage regulation & TAP change control



The MS2V164-S continuously monitors the transformer output voltage & current & provides RAISE & LOWER control commands to the on-load tap changer such that the load centre is automatically maintained within acceptable limits. Small variations in supply frequency will not affect the system performance.

When designing the MS2V164-S, considerable emphasis was placed on producing a relay, which would be very simple to install, set up & operate in the field. The result is a simple yet effective & very dependable voltage regulator relay available at a competitive price. The standard Micro MATRIX human machine interface (HMI) is combined with fully solid state voltage sensing & measuring circuitry to provide high accuracy, simple set up & flexible operation.

- Large graphics interface panel
- Line drop compensation with 1A & 5A CT inputs
- 63.5 & 110 VAC VT inputs
- Definite time & inverse time delays
- Independent fine & coarse voltage bandwidth windows
- Over & under voltage alarms
- Under voltage blocking function
- Tap change fail alarm
- 2 digital input load step stages
- Overcurrent blocking
- Self-diagnosis & fail alarm
- 2 load step stages
- Line voltage display
- Line current display
- Tap raise & lower event counter
- Rate of tap alarm
- Tap position indicator output
- Front panel USB PC programming port
- Non platform specific PC programming software
- Optical isolated RS485 & RS232 network port
- MODBUS RTU compatible network protocol
- Wide range of operating voltages

Options

- Auxiliary supply range
- Digital input operating voltage group 1
- Digital input operating voltage group 2
- Analogue outputs
- Rear communication port
- Application software

Technical data

Maximum make current	30 A
Maximum continuous current	5 A
Maximum switching voltage	300 VAC/VDC
Contact specification	1 C/O alarm contact
Auxiliary supply voltage	Wide range, refer to datasheet

Environmental data

Dimensions	MS4M56-S
Mounting	19" rack frame or flush
Operating temperature	-5 °C...+55 °C
Humidity	93 % RH non condensing, 40 °C

Detailed information and datasheets are available on www.morssmitt.com

MS1M122

Transformer parallel control system

The MS1M122 transformer parallel control system is designed to monitor & control the tap changers of up to 4 transformers connected on a common bus & operating in a MASTER FOLLOWER control configuration.

The tap position of each transformer is monitored as well as the raise / lower commands initiated by the selected master voltage regulating relay. Parallel control schemes are available to meet a range of transformer control configurations.

The MS1M122A is designed for applications where a separate & identical control cubicle is required for each transformer. Any transformer may be selected as INDEPENDENT, MASTER or FOLLOWER.

These systems are supplied fully wired in 19" sub rack frames ready for integration into customer panels.

General

- Simple system wiring
- Scalable up to 4 transformers
- Flexible control configuration et transformers in any combination of:
 - INDEPENDENT control
 - Parallel FOLLOWER
 - Parallel MASTER
 - OFF
 - Manual LOCAL control
 - Manual REMOTE control
- All standard uMATRIX features
- Size MS4M case

Control monitoring

- Tap change out of step alarm

Data display

- Tap raise & lower events
- Tap position indicator input for up to four (4) transformer tap changers
- Reference tap position indicator output
- Transformer 'In step' status

Communication

- Optical isolated RS232 PC link
- Non platform specific PC programming software
- Optical isolated RS485 or RS232 network port
- MODBUS RTU compatible network protocol

Environmental data

Housing	19" rack 4U high
Mounting	19" rack frame or flush
Operating temperature	-5 °C...+55 °C
Humidity	93 % RH non condensing, 40 °C

Detailed information and datasheets are available on www.morssmitt.com



Options

- Control system configuration
- Auxiliary supply range
- Status inputs
- Rear communication port
- Analogue outputs

Voltage regulation

MS4D200

TPI display module

The MS4D200 is a compact panel mount module incorporating 2 bright 25mm LED digits for the display of a power transformer tap position over the range TAP 1 to TAP 30.

The MS4D200 is specifically designed for operation with the MS2V200 TPI to frequency transducer. The MS2V200 provides a noise immune interface between the tap changer & the D200 via a 0 to 5 kHz frequency signal. Alternatively the MS4D200 may be configured to accept a BCD / BIN coded input direct from the tap changer or via a voltage to BCD / BIN transducer.

Where an MS2V164 voltage regulating relay is being used with a MS2V200 TPI transducer, the MS4D200 may be connected in parallel to provide a local easy to read tap position indication.

The MS4D200 may also be optionally specified to provide a BCD output of the tap position for interface to a SCADA system.

- Designed for interface with the MS2V200 TPI transducer
- Bright 25 mm digit red LED display
- Optional BCD input interface
- Optional BCD output signaling
- Compact panel mount case
- 12 VDC auxiliary supply input for use with isolated auxiliary supply module
- Simple & robust construction
- Non platform specific PC programming software
- Optical isolated RS485 & RS232 network port
- MODBUS RTU compatible network protocol
- Wide range of operating voltages

Options

- Output power rating
- I/O interface specification

Dimensions

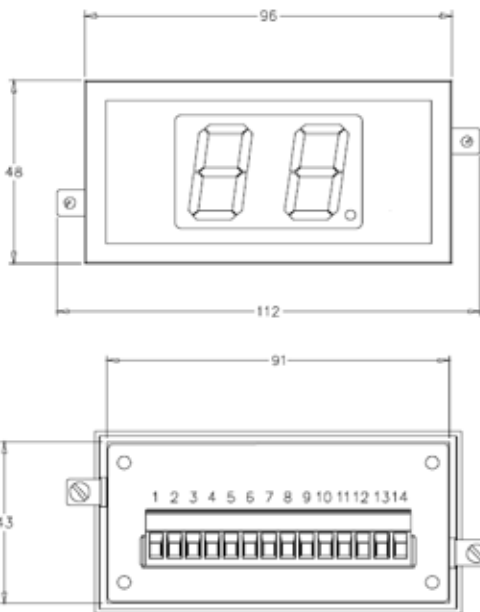

Technical data

Maximum make current	30 A (BCD contacts)
Maximum continuous current	5 A (BCD contacts)
Maximum switching voltage	660 VAC/VDC
Auxiliary supply voltage	12 VDC

Environmental data

Mounting	19" rack frame or flush
Operating temperature	-5 °C...+55 °C
Humidity	93 % RH non condensing, 40 °C

Detailed information and datasheets are available on www.morssmitt.com



SERVING
SAFETY

Auto reclose & synchronism check

Automatic reclose of the circuit breaker, after the fault clears, provides improved service continuity & system stability. An auto reclose relay provides for single or double shot automatic reclosing of circuit breakers, following interruption of supply due to a fault in the system.

Auto reclose & synchronism check

MS1B230

Multi shot auto reclose relay



The MS1B230 reclose relay provides for single & double shot automatic reclosing of circuit breakers, following interruption of supply due to a fault in the system.

Initiation of the MS1B230, resulting from the circuit breaker tripping, may be either a series (current input) or a shunt (voltage input) arrangement, as selected on site. After initiation the MS1B230 relay provides an adjustable time delay ('dead time') to allow the fault to clear, then gives a 2 s pulsed output reclose attempt signal. Immediately after this output pulse finishes, a 'lockout' timer element is initiated.

If the circuit breaker has not tripped after this interval has elapsed, the hold-in relay drops out & the reclose is completely de-energised.

- Single or double shot reclose with selectable auto reset mode
- Shunt initiate input
- Optional series initiate input
- Safe to reclose input
- Line voltage interlock
- CB reclose spring status input
- Drive to lockout input
- Independently adjustable dead time delay per shot

Options

- Auxiliary supply range
- 7 digit counter
- Series initiate input
- Status inputs
 - CB aux switch
 - Drive to lockout / reset lockout
 - Line volt monitoring
 - Spring charge / safe to close
 - Main protection shunt

Technical data

Maximum make current	30 A
Maximum continuous current	5 A
Maximum switching voltage	300 VAC/VDC
Contact specification	A/R in prog 1 C/O contact CB close sig. 1 1 C/O contact CB close sig. 2 1 C/O contact Block inst pr 1 C/O contact AR lockout 1 C/O contact Fail alarm 1 C/O contact
Auxiliary supply voltage	20...70 VDC or 40...300 VDC / 40...275 VDC
Time delay setting range	Reclose 1 5...180 s Reclose 2 5...180 s Reclaim time 5...180 s

Environmental data

Dimensions	MS4M56
Mounting	19" rack frame or flush
Operating temperature	-5 °C...+55 °C
Humidity	93 % RH non condensing, 40 °C

Detailed information and datasheets are available on www.morssmitt.com

MS2Y212-S

Synchronism check relay

The MS2SY212 synchronism check relay is designed to measure the phase angle between the monitored single phase voltages on the line & bus sides of a circuit breaker and verify that this angle is less than setting. If the measured angle has met this criteria for the time period defined by setting & the voltage magnitudes meet the criteria established by the Live Line/Bus & U/V Line/Bus settings, the output relay will be energised & the breaker permitted to close.

Resetting will occur if either the phase angle or voltage magnitude stray outside the pre-set limits or if the sync check enable input is de-energised. Front panel LEDs provide visual indication of relay status & sync check function.

- Synchronism check (25)
- Adjustable phase angle and time delay
- Flexible live and dead voltage configuration
- Bus or line U/V close block
- Voltage differential close block
- Frequency slip close block
- Flexible synchronism check bypass logic
- Manual safe to close feature
- USB programming port
- Modbus communication protocol



Options

- Auxiliary supply range
- Digital input
 - Operating voltage group 1
 - Operating voltage group 2
- Rear communications port

Technical data

Maximum make current	30 A
Maximum continuous current	5 A
Maximum switching voltage	300 VAC/VDC
Contact specification	Synchronise check close output 2 C/O Live line output 1 C/O Live bus output 1 C/O Undervoltage close block output 1 C/O Differential voltage close block 1 C/O Power sup. fail / CPU alarm 1 C/O
Adjustable time delay	0.1...100 s in 0.1 s steps
Auxiliary supply voltage	20...70 VDC or 40...300 VDC / 40...275 VDC

Environmental data

Dimensions	MS4M56-S
Mounting	19" rack frame or flush
Operating temperature	-5 °C...+55 °C
Humidity	95 % RH non condensing, 40 °C

Detailed information and datasheets are available on www.morssmitt.com

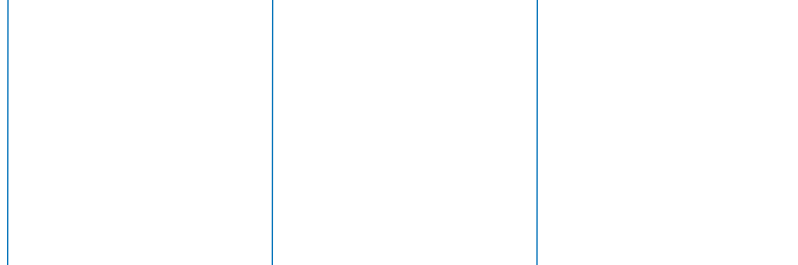



SERVING
SAFETY

Current monitoring

Current monitoring relays provide high speed overcurrent protection. AC or DC current sensing relays designed for high or low voltage power systems where they can be used in a large number of overcurrent applications.

Current monitoring

MS2C74

Busbar CT supervision and shorting



The MS2C74 relay provides high speed overcurrent protection for various items of power system plant such as frame earth leakage protection of metal clad switchgear & tank earth fault protection of substation power transformers.

The MS2C74 relay is a single phase device built in a compact MS2M draw out case suitable for rack and flush mounting. Where 3-phase monitoring is required, 3 single phase units should be employed. The relay measuring element is basically an attracted armature unit of simple & rugged construction. The operating coil of this unit is energised from a transformer which is tapped to provide 7 current settings. Setting is achieved using a plug bridge arrangement on the front panel..

- High speed operation
- High sensitivity
- 50 Hz or 60 Hz operation
- 7 Current settings using plug bridge
- Choose from 5 setting ranges
- ≤ 10 ms operation at 5x setting
- Hand reset mechanical flag
- 2 N/O or 4 N/O trip contacts
- Rugged attracted armature sensing element
- Use 3 independent units for 3-phase applications

Options

- Setting range
- Output contacts
- Rated frequency

Technical data

Maximum make current	30 A
Maximum continuous current	5 A
Maximum switching voltage	300 VAC/VDC
Contact specification	2 N/O or 4 N/O contacts
Operating time	≤ 10 ms at 5 x setting

Environmental data

Dimensions	MS2M28-S
Mounting	19" rack frame or flush
Operating temperature	-5 °C...+55 °C
Humidity	95 % RH non condensing, 40 °C

Detailed information and datasheets are available on www.morssmitt.com

MS2C200

Self-powered overcurrent relay



The MS2C200 is a self-powered overcurrent relay designed for protection applications with medium voltage ring main transformers (RMU's).

Application A: Overcurrent and short circuit/earth fault protection by combination of MS2C200 and circuit breaker. Overcurrent and short-circuit stage are tripped by the magnetic coil substitution for load break switch / fuse combination,

Application B: Overcurrent protection by combination of MS2C200 with load break switch and high voltage fuses; (tripping by MS2C200 disabled in range of short circuit current; disconnection by high voltage fuses) detects phase angle imbalance

- High accuracy numeric protection algorithm
- 'Set and forget' philosophy
- Integrated fault log
- Rack-mountable modular 19" rack system
- Automatic CT shorting when module is removed
- Extended range of additional modules (test sockets, supervision, protection)
- Self-test switch alarm contact for remote indication of watchdog alarm
- On-site test of function by test button
- Maintenance-free, power supply by current transformer
- Power supply buffered by lithium battery
- Live cycle > 15 years, if current transformers are not connected

Options

- Earth fault protection
- USB-port

Technical data

Pick-up current (3 ranges)

Range 1: 5...20 A
Range 2: 25...100 A
Range 3: 110... 260 A

Optional earth fault protection (3 ranges)

Range 1: 5...20 A
Range 2: 25...100 A
Range 3: 110... 260 A

Overcurrent level

Adjustable, refer to datasheet

Power supply

24...230 VDC

Buffered supply

Lithium battery

Automatic reset

After 2 hours / after restoration of supply

Manual reset

Front push button

Environmental data

Dimensions

MS2M28-S

Mounting

19" rack frame or flush

Operating temperature

-5 °C...+55 °C

Humidity

93 % RH non condensing, 40 °C

Detailed information and datasheets are available on www.morssmitt.com

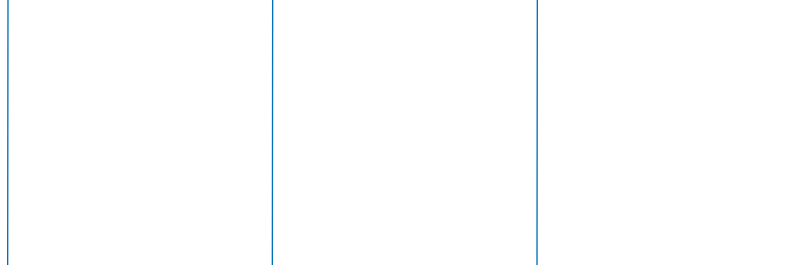



SERVING
SAFETY

Housing & dimensions

The housing has been specifically designed to meet the demanding & varied requirements for protection relay applications in power utility sub-station environments.

The standard 4U high 19-inch rack mounting modular configuration simplifies panel design & installation. Mounting points and overall panel dimensions meet international standards such that the cases may be interchanged with other similar types available on the market.

Optional CT shorting switches, blanking plates & 19" rack mount frames are also available. Blanking plates may be specially fabricated with cut outs & labeling to suit control switches, fuses, pilot lamps etc.

Housing & dimensions

MS40203

Empty diode box



The MS40203 diode box has been designed with flexibility in mind. The MS2M28-S case is suitable for either flush panel mounting or 19 inch 4U high rack mounting. The design utilises a draw out chassis for ease of installation & maintenance.

The MS40203 diode box is a metal construction for durability & screening from radiated electrical noise. Alternatively the case may be flush or projection mounted in either orientation (vertical or horizontal) as necessitated by the panel design.

- Sealable front cover
- IP5X category 2 dust protected and IP4X for solid ingress to IEC60529
- Size 2 housing
- 28 terminals
- 1/8 width
- 4U high
- Suitable for flush or panel mounting
- M4 screw terminations

Options

- Sealable

Environmental data

Housing

MS2M28-S

Mounting

19" rack frame or flush

Operating temperature

- 10 °C...+55 °C

Humidity

93 % RH non condensing, 40 °C



SERVING SAFETY

Housing & dimensions

MS2M28-S

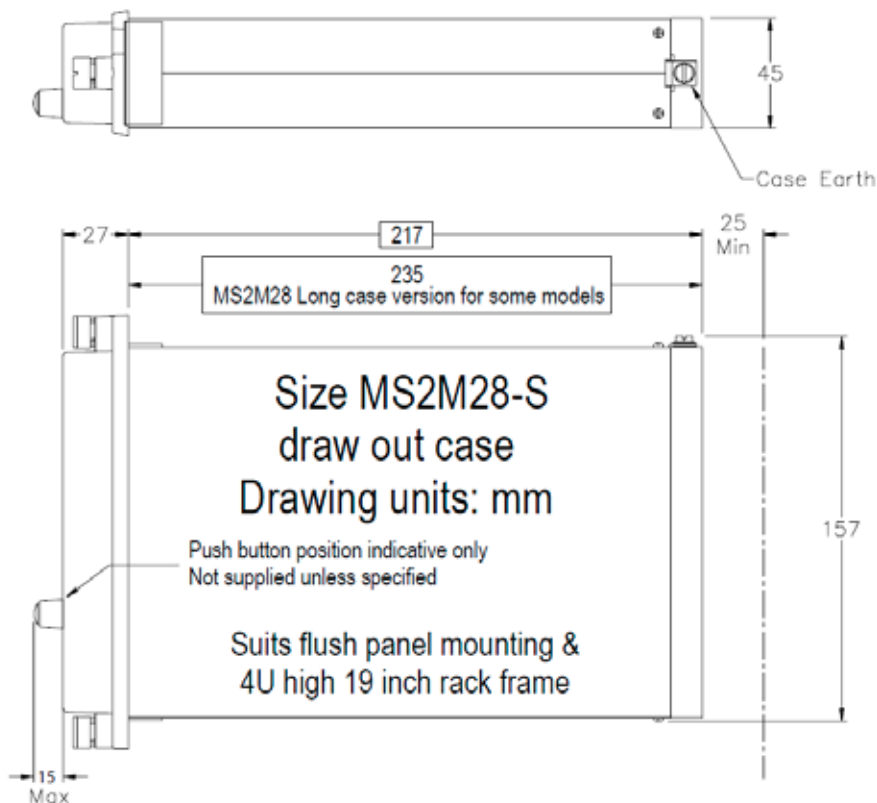

Options

- Size 2 housing
- 28 terminals
- 1/8 width
- 4U high
- Suitable for flush or panel mounting
- M4 screw terminations

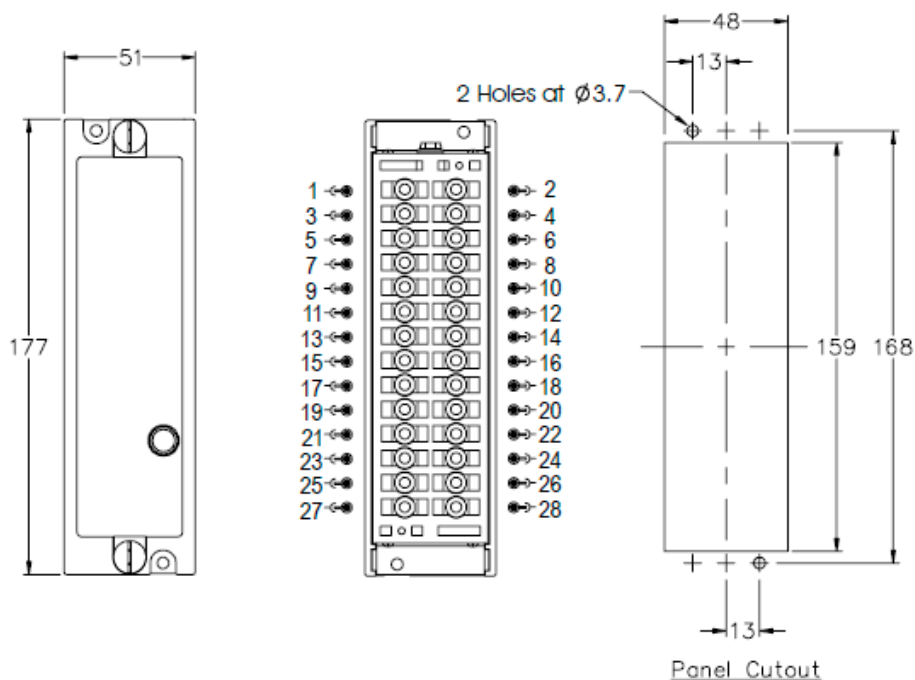

Housing & dimensions

MS4M28-S

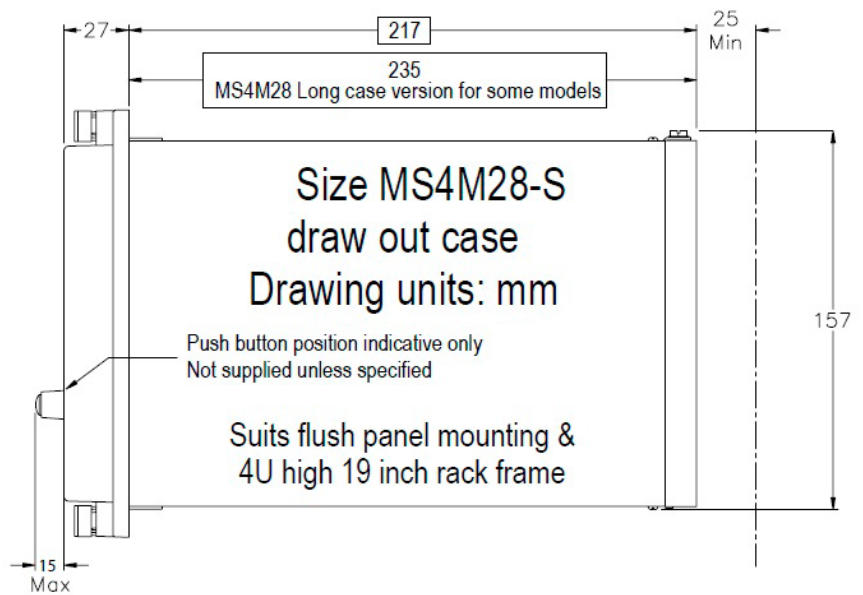
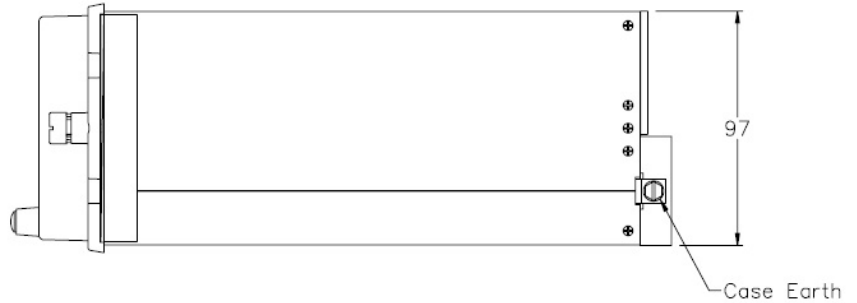
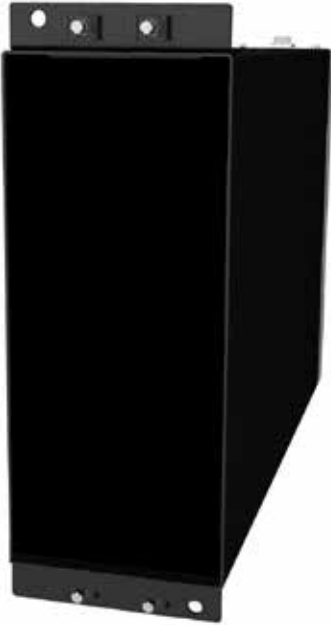

Options

- Size 4 housing
- 28 terminals
- 1/4 width
- 4U high
- Suitable for flush or panel mounting
- M4 screw terminations

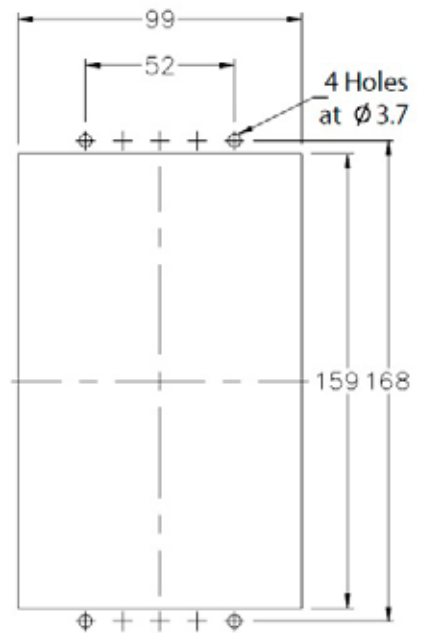
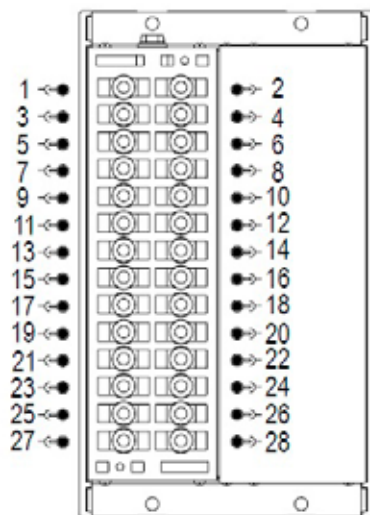
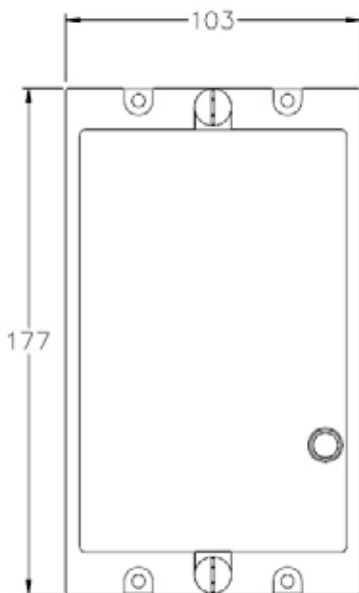



SERVING SAFETY

Housing & dimensions

MS4M56-S

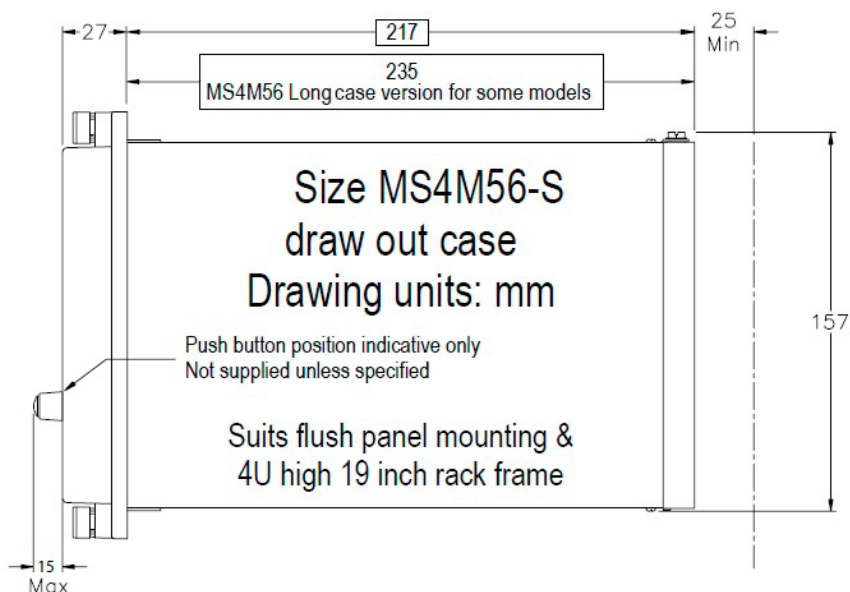
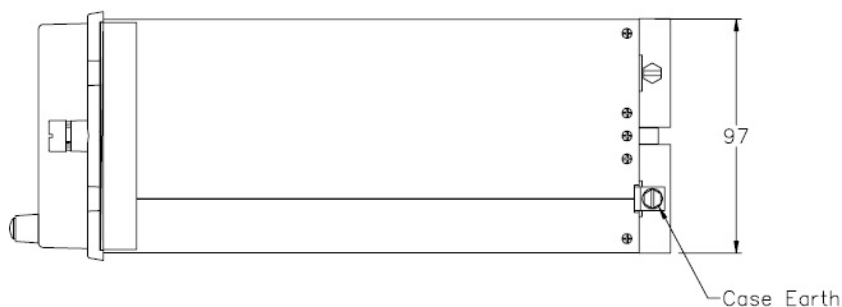
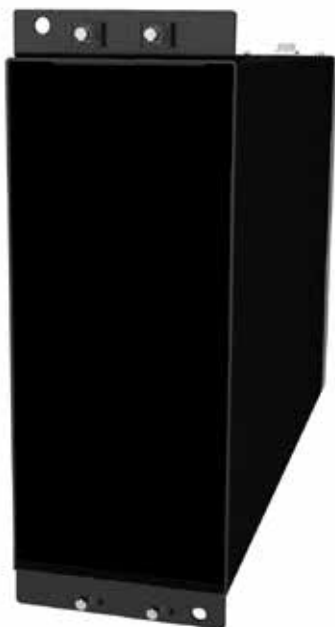

Options

- Size 4 housing
- 56 terminals
- 1/4 width
- 4U high
- Suitable for flush or panel mounting
- M4 screw terminations

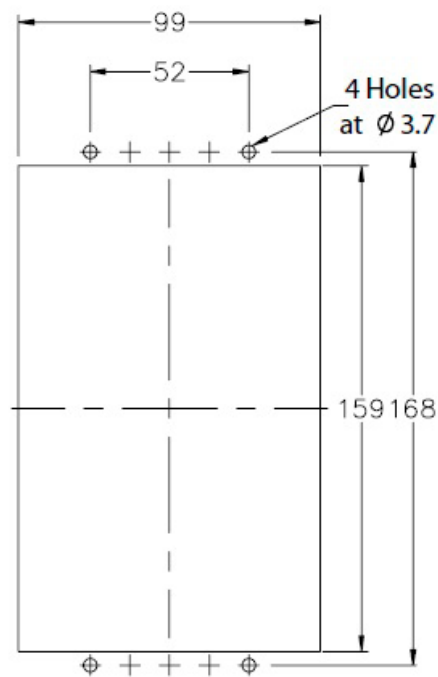
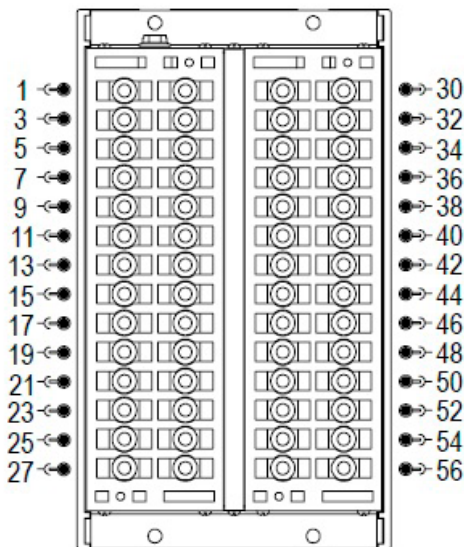
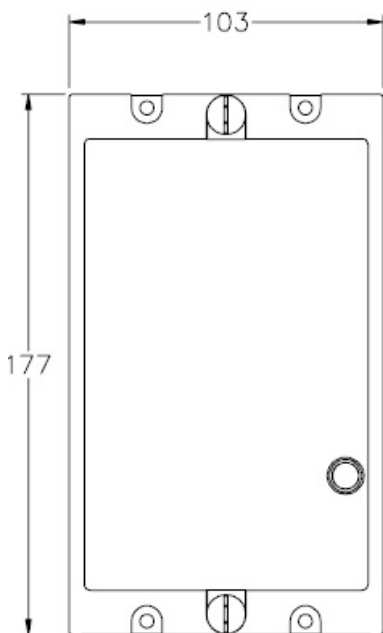



SERVING
SAFETY

Mors Smitt Industrial Technology

High performance electromechanical relays

SALES OFFICES

FRANCE

Mors Smitt France SAS
Tour Rosny 2, Avenue du Général de Gaulle,
F - 93118 Rosny-sous-Bois Cedex, France
T +33 (0) 1 4812 1440
F +33 (0) 1 4855 9001
E sales@msrelais.com

HONG KONG

Mors Smitt Asia Ltd.
807, Billion Trade Centre, 31 Hung To Road
Kwun Tong, Kowloon, Hong Kong SAR
T +852 2343 5555
F +852 2343 6555
E info@morssmitt.hk

THE NETHERLANDS

Mors Smitt B.V.
Vrieslantlaan 6
3526 AA Utrecht, The Netherlands
T +31 (0)30 288 1311
F +31 (0)30 289 8816
E sales.msbv@wabtec.com

UNITED KINGDOM

Mors Smitt UK Ltd.
Doulton Road, Cradley Heath
West Midlands, B64 5 QB, UK
T +44 (0)1384 567 755
F +44 (0)1384 567 710
E sales.msuk@wabtec.com

USA

Mors Smitt Technologies Inc.
1010 Johnson Drive
Buffalo Grove, IL 60089-6918, USA
T +1 847 777 6497
F +1 847 520 2222
E salesmst@wabtec.com

Your local contact

BRO-Actus V1.0 Nov 2013

www.morssmitt.com

