

/// Plug-in railway relay with 4 contacts

Rugged plug-in relays for extreme reliability, within long endurance applications and harsh environments

D-U200-W

Instantaneous relay, weld-no-transfer, 4 pole
Part of D-platform

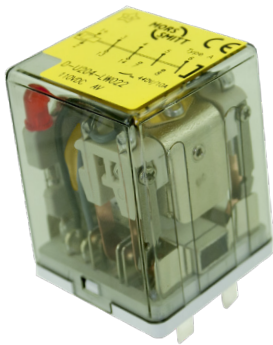

Description

Plug-in safety critical railway relay with 4 N/O-N/C contacts. Weld-no-transfer contacts are standard, to always guarantee a safe and reliable response also in case of an error. It is equipped with back EMF suppression diode (for DC voltages) and magnetic arc blow-out for high breaking capacity and long contact life. Optionally with double make/ double break contacts to further increase the breaking capacity and contact life. Proven reliable operation in switching high DC voltage / inductive loads and low currents. No external retaining clip needed as integrated 'snap-lock' will hold relay into socket under all circumstances and mounting directions.

The construction of the relay and choice of materials makes the D-U200-W relay suitable to withstand corrosive atmospheres, low and high temperatures, shock & vibration and dry to very humid environments.

Compact design, choice of many options and a wide range of sockets makes the D-U200-W relay an easy and flexible solution to use.

Application

Rugged plug-in relays for safety critical, extreme reliable and long endurance applications in harsh environment.

These relays are designed for demanding rolling stock applications such as door control, traction control, braking systems etc.

Features

- Compact plug-in design
- Instantaneous, 4 N/O - N/C contacts
- Weld-no-transfer (WNT) contacts
- Standard back EMF suppression diode
- Magnetic arc blow-out
- Flat, square silver plated relay pins for excellent socket connection
- Wide range sockets
- Integrated snap lock
- Transparent cover
- High DC breaking capacity
- Flexibility by many options
- Positive mechanical keying relay to socket

Connection diagram

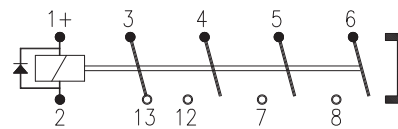

D-U200-W013 relay
 contact combination
 1 N/C 3 N/O

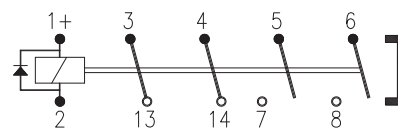

D-U200-W022 relay
 contact combination
 2 N/C 2 N/O

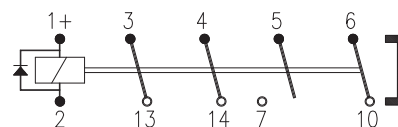

D-U200-W031 relay
 contact combination
 3 N/C 1 N/O

(More specific information on page 3)

Timing diagram

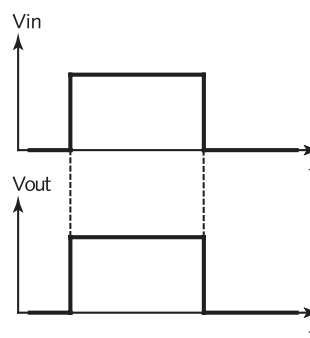

Railway compliancy

EN 50155	EN 50121
IEC 60571	EN 45545-2
IEC 60077	NF F16-101/102
IEC 60947	NF F 62-002
IEC 61373	IEC 60529



Instantaneous relay D-U200-W

Options

- Low temperature (-50 °C), max. contact current 8 A
- Gold plated contacts
- Special dust protection
- LED coil indicator
- Bipolar LED indicator
- AgSnO₂ contacts, high resistant to welding
- No magnetic arc blow-out
- Polarisation diode
- Double zener diode
- Coil for both AC and DC
- Double make / double break contacts (-50 °C)
- No diode
- Make before break contact
- Keying

Remark: Not all combinations possible

Dimensions (mm)

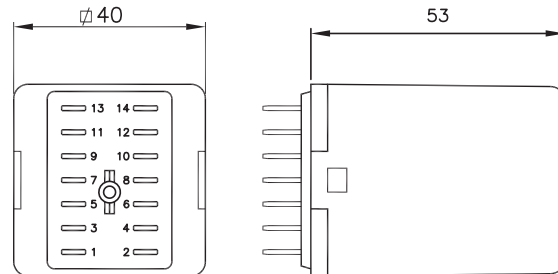

Sockets

		Mounting			
		Surface / Wall	35 mm rail	Panel / Flush	PCB
Terminal connection	Screw	V23	V23	-	-
	Screw - wide terminals	V22 BR	V23 BR	-	-
	Spring clamp	V29	V29	V33	-
	Faston	-	-	V31	-
	Crimp	-	-	V26	-
	Solder tag	-	-	V3	-
	PCB	-	-	-	V32

For more information see the respective datasheets

For more detailed technical specifications, drawings and ordering information, go to the product page on www.morssmitt.com

 **Over 10 million Mors Smitt relays in use in rail transport applications worldwide!**

Mors Smitt Asia Ltd.
 Unit B & C, 25/F., Casey Aberdeen House
 38 Heng Yip Road, Wong Chuk Hang
 Hong Kong
 Tel: +852 2343 555
sales.msa@wabtec.com

Mors Smitt France SAS
 2 Rue de la Mandinière
 72300 Sablé-sur-Sarthe, France
 Tel: +33 (0) 243 92 82 00
sales.msfr@wabtec.com

Mors Smitt UK Ltd.
 Graycar Business Park,
 Burton on Trent, DE13 8EN, UK
 Tel: +44 (0)1283 357 263
sales.msuk@wabtec.com

Wabtec Netherlands B.V.
 Vrieslantlaan 6,
 3526 AA, Utrecht, Netherlands
 Tel: +31 (0)30 288 1311
sales.msbv@wabtec.com

Mors Smitt Technologies Ltd.
 1010 Johnson Drive,
 Buffalo Grove, IL 60089-6918, USA
 Tel: +1 847 777 6497
salesmst@wabtec.com

RMS Mors Smitt
 19 Southern Court,
 Keysborough, VIC 3173, Australia
 Tel: +61 (0)3 8544 1200
sales.rms@wabtec.com

(c) Copyright 2020

All rights reserved. Nothing from this edition may be multiplied, or made public in any form or manner, either electronically, mechanically, by photocopying, recording, or in any manner, without prior written consent from Mors Smitt. This also applies to accompanying drawings and diagrams. Due to a policy of continuous development Mors Smitt reserves the right to alter the equipment specification and description outlined in this datasheet without prior notice and no part of this publication shall be deemed to be part of any contract for the equipment unless specifically referred to as an inclusion within such contract. Mors Smitt does not warrant that any of the information contained herein is complete, accurate, free from potential errors, or fit for any particular purpose. Mors Smitt does not accept any responsibility arising from any party's use of the information in this document.

Instantaneous relay D-U200-W

Technical specifications

Connection diagram

Bottom view relay

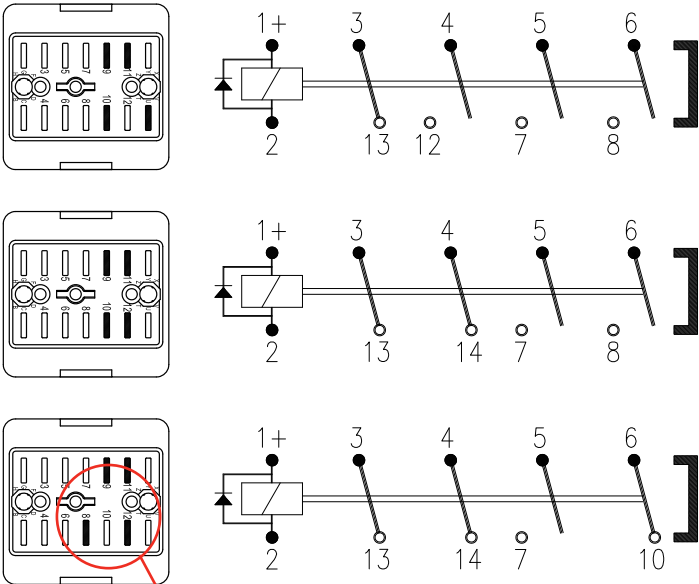

D-U200-W013 relay contact combination 1 N/C 3 N/O

D-U200-W022 relay contact combination 2 N/C 2 N/O

D-U200-W031 relay contact combination 3 N/C 1 N/O

No relay pins are placed at the black marked pin positions.

Top view socket

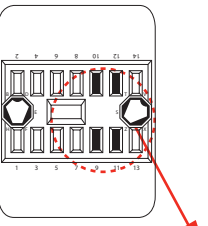

At the black marked positions the holes in the socket are blocked, so no relay pin can enter. Only correct contact configuration of the D-U200-W0XX model will fit.

Additional standard keying see page 13

Instantaneous relay D-U200-W

Coil characteristics

Inductance L/R at Unom (typical value):	
Energized	11 ms
Released	8 ms
Nominal power consumption	2.2 W @ Unom
Operating voltage range	0.7 - 1.25 Unom

Type	Unom (VDC)	Umin (VDC)	Umax (VDC)	Udrop-out (VDC)	Rcoil * (Ω)	Icoil-nom (mA)
D-U201-W	24	16.8	30	2.4	270	89
D-U202-W	48	33.6	60	4.8	1046	46
D-U203-W	72	50.4	90	7.2	2406	30
D-U204-W	110	77	137.5	11	5330	21
D-U205-W	96	67.2	120	9.6	4150	23
D-U206-W	12	8.4	15	1.2	72	167
D-U207-W	36	25.2	45	3.6	562	64
D-U210-W	120	84	150	12	6160	19
D-U213-W	125	87.5	156.25	12.5	7634	16
D-U215-W	220	154	275	22	21776	10
D-U220-W	250	175	312.5	25	23850	10

Other types on request

* The Rcoil is measured at room temperature and has a tolerance of $\pm 10\%$, with option L (LED) the value can differ

Remarks:

- Umin is the must-operate voltage at which the relay has picked up in all circumstances (worst-case situation), in practice the relay picks up at a lower voltage
- Udrop-out is the must-release voltage at which the relay has dropped-out in all circumstances (worst-case situation), in practice the relay drops out at a higher voltage
- Always select the nominal voltage as close as possible to the actual voltage in the application

Operating range at various temperatures

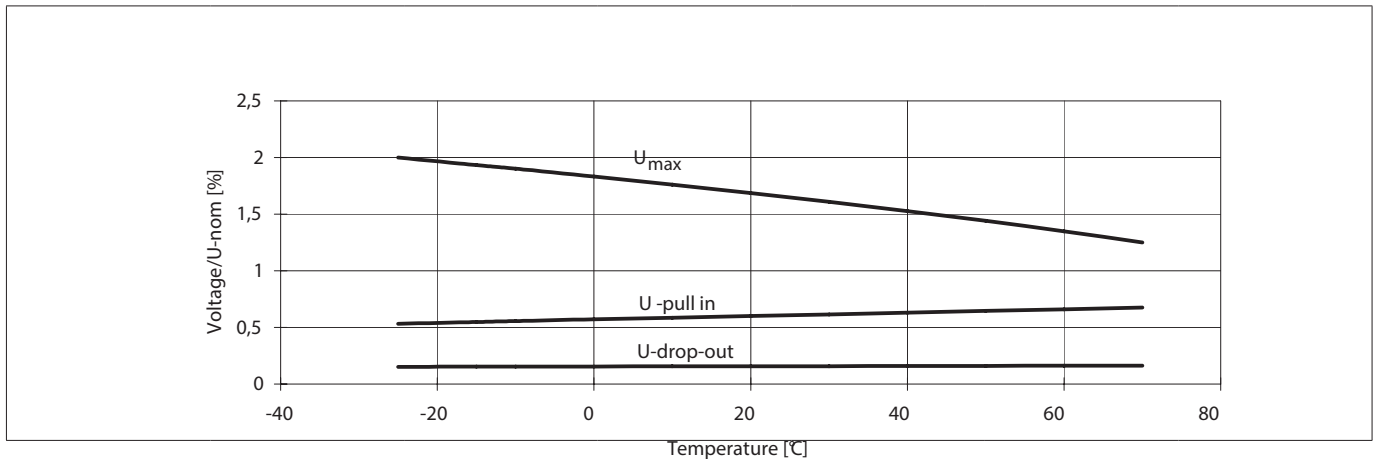

Remark: In June 2019 the coil tape color is changed to yellow. This change has no effect on any of the relay specifications or technical performance.

Instantaneous relay D-U200-W

Contact characteristics

Amount and type of contacts	4 N/O - N/C
Maximum make current	16 A
Peak inrush current	NF F 62-002 200 A (withstand > 10 x 200 A @ 10 ms, 1 min)
Maximum continuous current	10 A
Maximum switching voltage	250 VDC, 440 VAC
Minimum switching voltage	12 V
Minimum switching current	10 mA
Maximum breaking capacity (> 50.000 operations)	72 VDC, 5 A (L/R ≤ 40 ms) 110 VDC, 10 A (resistive load) 110 VDC, 0.5 A (L/R ≤ 40 ms)
Contact resistance	15 mΩ (initial)
Material	Ag standard (optional AgSnO ₂ , Au on Ag)
Contact gap	≥ 1.5 mm
Contact force	> 200 mN

Electrical characteristics

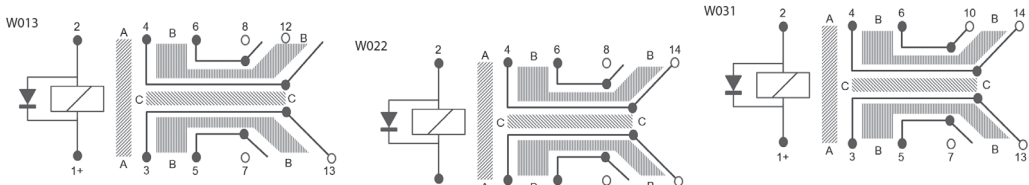
Insulation coordination				
				
Section	Clearance	Creepage	Material group	Unom*
A	≥ 2.2	≥ 3.0	I (CTI600)	220 V
B	≥ 2.4	≥ 2.4	I (CTI600)	240 V
C	≥ 1.7	≥ 1.7	I (CTI600)	170 V
* For basic insulation, PD2 and OV3				
Pulse withstanding	IEC 60255-5		5 kV (1.2/50 μs)	

Mechanical characteristics

Mechanical life	50 x 10 ⁶ operations
Maximum switching frequency	Mechanical: 3600 ops/h Electrical: 1200 ops/h
Weight	145 g

Instantaneous relay D-U200-W

Environmental characteristics

Environmental	EN 50125-1, IEC 60077-1
Vibration	IEC 61373, Category I, Class B, Body mounted
Shock	IEC 61373, Category I, Class B, Body mounted
Operating temperature	-25 °C...+85 °C (optional: -50 °C)
Humidity	95% (condensation is permitted temporarily)
Maximum altitude	2000 meter. Higher altitudes are possible but have consequences mentioned in IEC 60664 (for example 5000 meter with bigger clearance distance)
Salt mist	IEC 60068-2-11, class ST4
Damp heat	IEC 60068-2-30, Test method Db variant 1
Protection	IEC 60529, IP40 (relay on socket) (with option K: IP50)
Fire & smoke	NF F 16-101, NF F 16-102, EN 45545-2: HL3 for requirements R22, R23, R26
Insulation materials	Cover: polycarbonate Base: polyester

Railway compliancy

EN 50155	Railway applications - Rolling stock - Electronic equipment
IEC 60571	Railway applications - Electronic equipment used on rolling stock
IEC 60077	Railway applications - Electric equipment for rolling stock
IEC 60947	Low-voltage switchgear and controlgear
IEC 61373	Railway applications - Rolling stock equipment - Shock and vibration tests
EN 50121	Railway applications - Electromagnetic compatibility
NF F16-101/102	Railway rolling stock - Fire behavior
EN 45545-2	Railway applications - Fire protection on railway vehicles Part 2: Requirements for fire behavior of materials and components
IEC 60529	European standard describes the protection class (IP-code)
NF F 62-002	Railway rolling stock - On-off contact relays and fixed connections

Instantaneous relay

D-U200-W

Options

Code	Description	Remark	Cannot be combined with:
Standard options:			
C	Low temperature (-50 °C)	Icontact < 8 A	
E*	Au; Gold plated contacts (10 µm)	Yellow tape around relay for identification (option X6)	M
K	Extra dust protection	IP50 Cat 2 for the relays mounted in a Mors Smitt socket. Application PD1/PD2 and contact load > 0.5 A.	
L	LED integrated in coil		X2
N	No magnetic arc blow-out		
Q	Double zener diode over coil	Maximum allowed peak voltage 180 V, higher voltage will damage the diode	
Y	Double make/double break contacts	YW012: NC3-13, NO5-7, NO*8-12 YW011: NC*13-14, NO*7-8 YW021: NC3-13, NO5-7, NC*10-14 *double make /double break contacts	
Z	No diode	Polarity independent	
Keying	Coil coding relay and socket		

Special options:

M	AgSnO ₂ ; "non-weldable" contacts	Icontact > 100 mA	E
P	Polarisation diode		
X2	AC/DC rectifier bridge		L
X6	Yellow tape around relay for identification		

* Gold plated contacts characteristics

Material	Ag, 10 µm gold plated
Maximum switching voltage	60 V (higher voltages may be possible, contact Mors Smitt for more information)
Maximum switching current	400 mA (at higher rate gold will evaporate, then the standard silver contact rating of minimum 10 mA and 12 V is valid)
Minimum switching voltage	5 V
Minimum switching current	1 mA

Remark: For application support or technical product support, contact your local Mors Smitt sales office (see contact details on last page).

Instantaneous relay D-U200-W

Electrical life expectancy

Due to the safety nature of the D-U200-W relays, please contact Mors smitt with detailed contact load data. With this information, Mors Smitt can provide a correct advice in line with your specific application.

Required contact data:

- Voltage
- Current
- Inductance of load
- Kind of suppression used on load
- Required number of operations
- Switching frequency

Weld-no-transfer

The most obvious difference to standard relays is the so called forcibly guided contacts. The minimum requirements for such a contact set is that it consists of at least one N/C contact and one N/O contact. The contacts are mechanically linked, so that N/O and N/C contacts can never be closed at the same time.

Weld-no-transfer (forcibly guided) contacts makes it impossible to close the normally closed and normally open contact simultaneously. If a normally closed contact becomes welded, it is impossible for the normally open contacts to close when the coil is energized. If a normally open contact becomes welded, it is impossible for the normally closed contacts to close when the coil is de-energized.

If a contact welds, a guide (counter blades) stops movement of the contact block to ensure other contacts cannot close.

Weld-no-transfer relays are the connecting link between the load and monitoring circuits; they act as a monitoring element in electronics for functional safety.

Weld-no-contact feature is primarily required for safety circuits and redundant control systems. With a forcibly guided relay its welding state can be detected and allows determination by the control circuit if contacts are welded together.

When the N/O contact carries the load, the N/C contact can be used as monitoring contact. The monitoring contact will not close when the N/O contact is welded.

The D-U200-Wxxx relay with weld-no-transfer contacts complies to the standards NF F62-002 (§12.3.10) and meets the technical requirements listed in the EN 50205 standard as described below.

Testing according to NF F62002 §12.3.10:

- With one N/C contact kept closed, none of the N/O contacts may close a test circuit of 10 mA @ 220 V 50 Hz when the coil is energized with 150 % of the maximum specified coil voltage ($= 150 \% * 125 \% U_{nom} = 188 \% U_{nom}$). The other N/C contacts may open.
- With one N/O contact kept closed, none of the N/C contacts may close a test circuit of 10 mA @ 220 V 50 Hz when the coil is de-energized. The other N/O contacts may open.

Testing according to EN50205:

- If one N/C contact fails to open, all N/O contacts must maintain a contact gap ≥ 0.5 mm when the coil is energized with the maximum energizing quantity which can occur under worst case conditions:
 - maximum coil voltage
 - minimum ambient temperature
 - minimum coil resistance
- If one N/O contact fails to open, all N/C contacts must maintain a contact gap ≥ 0.5 mm when the coil is de-energized
- All tests must be performed under worst case conditions
- Above requirements apply throughout the specified endurance and under reasonable foreseeable single failure conditions
- Failure mode and effect analysis (FMEA) has been performed to verify the design

Safety related application condition

In case the relays are used in safety relevant application conditions the relays shall be used in applications where the contacts are read back within a two channel safety structure.

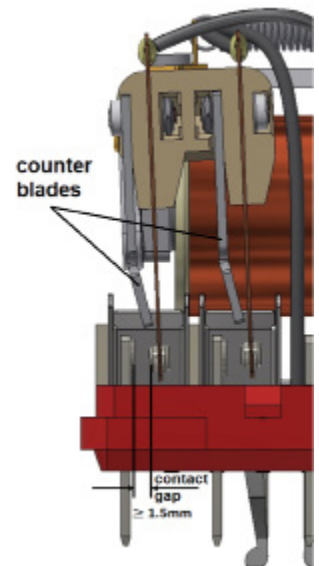

Instantaneous relay D-U200-W

Mounting possibilities/sockets



Surface/wall mounting

338000302	V22BR	Screw socket, wall mount, front connection (9 mm terminals)
338000580	V23	Screw socket, wall mount, front connection (7.5 mm terminals)
338000610	V29	Spring clamp socket, wall mount, front dual connection (2.5 mm ²)

Rail mounting

338000580	V23	Screw socket, rail mount, front connection (7.5 mm terminals)
338000402	V23BR	Screw socket, rail mount, front connection (9 mm terminals)
338000610	V29	Spring clamp socket, rail mount, front dual connection (2.5 mm ²)

Panel/flush mounting

338100100	V3	Solder tag socket, panel mount, rear connection
328400100	V26	Crimp contact socket, panel mount, rear connection, A260 crimp contact
338000560	V31	Faston connection socket, rear dual connection (4.8 x 0.8 mm)
338000570	V33	Spring clamp socket, flush mount, rear dual connection (2.5 mm ²)

PCB mounting

338000561	V32	PCB soldering socket
-----------	-----	----------------------

No external retaining clip needed as the 'snap-lock' will hold the relay into the socket under all circumstances and mounting directions (according shock & vibration requirements IEC 61373, Category I, Class B, Body mounted). If regulations require external retaining clips, these are available as well.

For more details see datasheets of the sockets on www.morssmitt.com

Instantaneous relay D-U200-W

Mechanical keying relay and socket (optional)

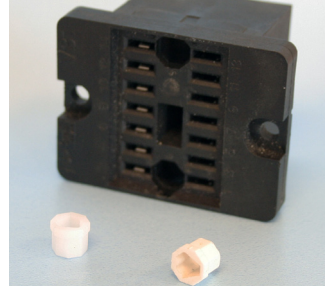

Function:

- To prevent wrong installation
- To prevent damage to equipment
- To prevent unsafe situations

For D-U200-W relay the mounting plate contains fewer pins, therefore there is already a keying built in between the various types of weld-no-transfer configurations. At the black marked positions, the holes in the socket are blocked (with inserts), so no relay pin can enter. Additional mechanical keying system can be used (optionally) to prevent a relay is inserted in a wrong socket.

For example it prevents that a 24 VDC relay is put in a 110 VDC circuit. Positive discrimination is possible per different function, coil voltage, timing, monitoring, safety and non-safety.

The D relay socket keying option gives $8 \times 8 = 64$ possibilities. Upon ordering the customer simply indicates the need for the optional keying. Mors Smitt will assign a code to the relay and fix the pins into the relay. The sockets are supplied with loose key receptacles. Inserting the keys into the socket is very simple and self explaining.

Remark: Sockets and relay shown are examples.

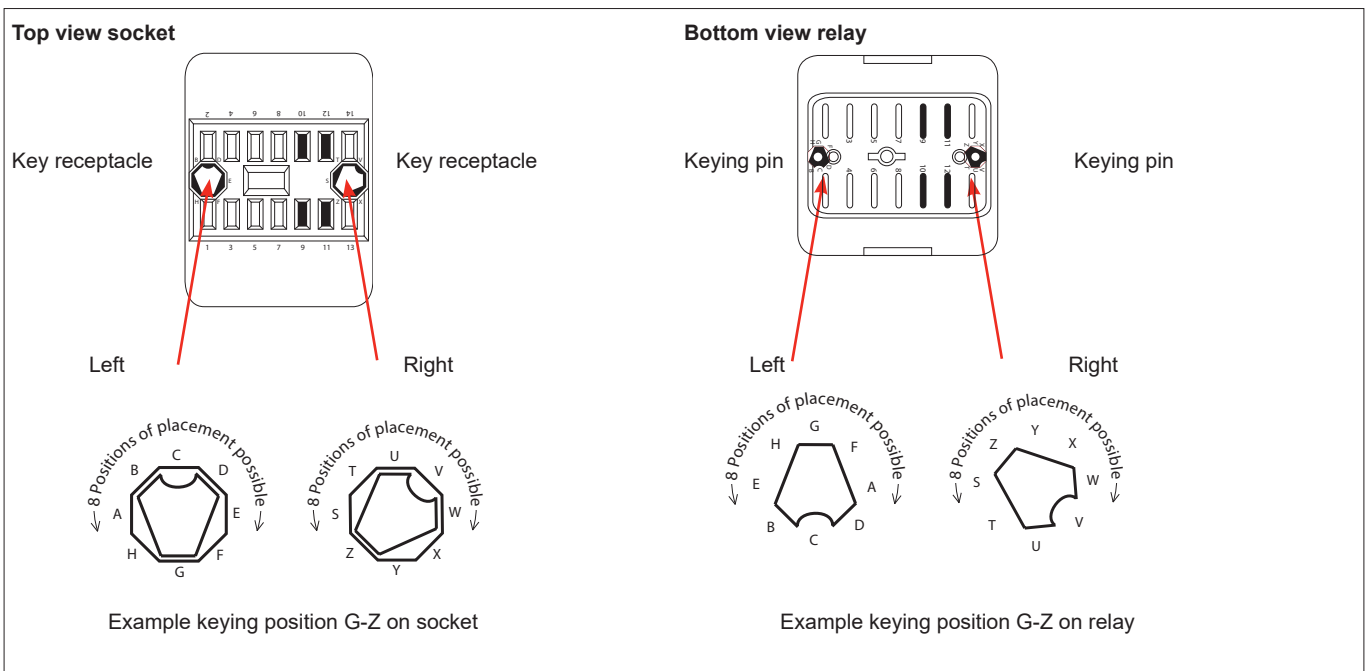

Instantaneous relay D-U200-W

Important for relay selection and operation

Make sure the relay is suitable for the application. For critical applications (for example: green loop applications) relays should be checked on correct working during periodic inspection.

Recommendations for long time contact reliability

For relays to enable failure free performance over a very long operational time, it is important to create the right circumstances. In any relay, contact usage and atmospheric conditions influence the contact surface. To counter this effect it is common practice to use a safety factor of > 2 to ensure long time contact reliability.

Therefore for long time contact reliability we recommend:

- Silver contacts: a minimum contact current of 20 mA per contact
- Gold contacts: a minimum contact current of 10 mA per contact
- Double Make Double Break contacts: a minimum contact current of 40 mA per contact
- When low currents are switched and not frequently, e.g. 10 mA once a day, it is advised next to gold plated contacts to put similar contacts within the same relay in parallel
- With higher load switching, e.g. 110 VDC and > 1 A, put relay contacts in series
- Rule of thumb: any relay works best with switching currents > 20 mA in DC environment when frequently switched. When not switched frequently a higher switching current like 50 mA is better for a long reliable operational time
- Check relays regularly, for example with the Mors Smitt Portable Relay Tester and visually through the transparent cover

Instructions for use

Installation

Before installation or working on the relay: disconnect the power supply first (no hot swapping)! Install socket and connect wiring according to the terminal identification. Plug relay into the socket ensuring there is no gap between the bottom of relay and the socket. Reverse installation into the socket is not possible due to the mechanical blocking snap-lock feature. Check to ensure that the coil connection polarity is not reversed. Relays can be mounted tightly together to save space. When rail mounting is used, always mount the socket in the direction of the UP arrow, to have proper fixation of the socket on the rail.

Warning!

- Never use silicon in the proximity of the relays
- Do not use the relay in the presense of flammable gas as the arc generated from switching could cause ignition
- To remove relays from the socket, employ up and down lever movements. Sideway movement may cause damage to the coil wires

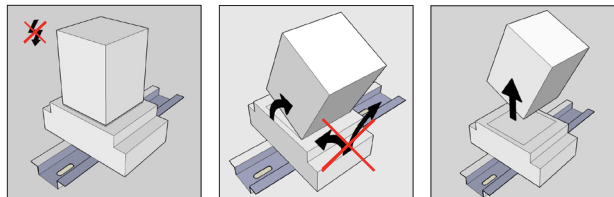

- Relays should never be swapped to other circuit positions when taken out of its socket for inspection or fault finding, always place it back into the original position to prevent contact resistance problems. Contact resistance problems can be created when swapping relays between different circuit loads due the contact wear/condition having changed during its operational life.

Operation

After installation always apply the rated voltage to the coil to check correct operation. Long term storage may corrode the silver on the relay pins. When plugging the relay into the socket, the female bifurcated or trifurcated receivers will automatically cut through the corrosion on the pins and guarantee a reliable connection.

Before actual use of relays, it is advised to switch the load several times with the contacts. The contacts will both be electrically and mechanically cleaned due to the positive wiping action. Sometimes a contact can build up increased contact resistance (≤ 15 m Ω when new). When using silver contacts one can clean the contact by switching a contact load a few times using >24 VDC & ~ 2 A. Increased contact resistance is not always problematic, as it depends on circuit conditions. In general a contact resistance of 1 Ω is no problem, consult Mors Smitt for more information.

Condensation in the relay is possible when the coil is energised (warm) and the outside, environmental temperature is cold. This is a normal phenomenon and will not affect the function of the relay. Materials in the relay have no hygroscopic properties.

Instantaneous relay D-U200-W

Inspection / maintenance

Correct operation of the relay can easily be checked as the transparent cover provides good visibility of the moving contacts. If the relay does not seem to operate correctly, check for presence of the appropriate coil voltage and polarity using a suitable multimeter. If a LED is fitted, it indicates voltage presence to the coil. If coil voltage is present, but the relay does not operate, a short circuit of the suppression diode is possible (This may have been reversed due to the coil connection).

Relays can easily be tested with the Mors Smitt Relay Tester. More information on: www.morssmitt.com.

If the relay doesn't work after inspection, replace the relay unit with a similar model. Do not attempt to open the relay cover or try to repair. Contacts are calibrated and in balance, touching can affect proper operation. Also resoldering may affect correct operation. Since 2009 relays have tamper proof seals fitted and once broken, warranty is void.

Most relay defects are caused by installation faults such as overvoltage, spikes/transients, high/short current far exceeding the relay specifications. When returning the relays for investigation, please provide all information on the RMA form. Send defective relays back to the manufacturer for repair or replacement. Normal wear and tear or external causes are excluded from warranty.

RMA procedure see www.morssmitt.com

Instantaneous relay D-U200-W

Ordering scheme

D-U2		-		Code		
Coil voltages	01				24 VDC	
	02				48 VDC	
	03				72 VDC	
	04				110 VDC	
	05				96 VDC	
	06				12 VDC	
	07				36 VDC	
	10				120 VDC	
	13				125 VDC	
	15				220 VDC	
20				250 VDC	Cannot be combined with:	
Options (add as many options as needed)	C				Low temperature (-50 °C) - Max contact current 8 A	
	E				Gold plated contacts	M
	K				Extra dust protection, IP50	
	L				LED coil indicator	X2
	N				No magnetic arc blow-out	
	Q				Double zener diode	
	Y				Double make/ double break (-50 °C)	
	Z				No diode	
Special options (minimum order quantity: 20)	M				AgSnO ₂ contacts, highly resistant to welding	E
	P				Polarisation diode	
	X2				Coil for both DC and AC	L
Contact information (Double make / double break)			W013		Weld-no-transfer, 1 N/C - 3 N/O (option Y: YW012: N/C 3-13, N/O 5-7, N/O 8-12)	
			W022		Weld-no-transfer, 2 N/C - 2 N/O (option Y: YW011: N/C 13-14, N/O 7-8)	
			W031		Weld-no-transfer, 3 N/C - 1 N/O (option Y: YW021: N/C 3-13, N/O 5-7, N/C 10-14)	
Keying code - Optional, leave blank if not required - Keying codes are available for all possible coil voltages					Standard, silver contacts	
	AS	24 VDC			D-U201 code AS	
	AY	36 VDC			D-U207 code AY	
	AT	48 VDC			D-U202 code AT	
	AU	72 VDC			D-U203 code AU	
	AV	110 VDC			D-U204 code AV	
					Option E, gold contacts	
	DT	24 VDC			D-U201-E code DT	
	FV	36 VDC			D-U207-E code FV	
	HU	48 VDC			D-U202-E code HU	
	AZ	72 VDC			D-U203-E code AZ	
	HV	110 VDC			D-U204-E code HV	
					Option M, silver tin oxide contacts	
	GT	24 VDC			D-U201-M code GT	
	HT	36 VDC			D-U207-M code HT	
GU	48 VDC			D-U202-M code GU		
GV	72 VDC			D-U203-M code GV		
GW	110 VDC			D-U204-M code GW		

Example: D-U201-C W013 code AS

Description: D-U200 relay, Unom: 24 VDC, low temperature (-50 °C), weld-no-transfer 1 N/C - 3 N/O, keying code AS

Instantaneous relay
D-U200-W

 **Over 10 million Mors Smitt relays in use in rail transport applications worldwide!**

Mors Smitt Asia Ltd.
Unit B & C, 25/F., Casey Aberdeen House
38 Heng Yip Road, Wong Chuk Hang
Hong Kong
Tel: +852 2343 555
sales.msa@wabtec.com

Mors Smitt France SAS
2 Rue de la Mandinière
72300 Sablé-sur-Sarthe, France
Tel: +33 (0) 243 92 82 00
sales.msf@wabtec.com

Mors Smitt UK Ltd.
Graycar Business Park,
Burton on Trent, DE13 8EN, UK
Tel: +44 (0)1283 357 263
sales.msuk@wabtec.com

Wabtec Netherlands B.V.
Vrieslantlaan 6,
3526 AA, Utrecht, Netherlands
Tel: +31 (0)30 288 1311
sales.msbv@wabtec.com

Mors Smitt Technologies Ltd.
1010 Johnson Drive,
Buffalo Grove, IL 60089-6918, USA
Tel: +1 847 777 6497
salesmst@wabtec.com

RMS Mors Smitt
19 Southern Court,
Keysborough, VIC 3173, Australia
Tel: +61 (0)3 8544 1200
sales.rms@wabtec.com

(c) Copyright 2020

All rights reserved. Nothing from this edition may be multiplied, or made public in any form or manner, either electronically, mechanically, by photocopying, recording, or in any manner, without prior written consent from Mors Smitt. This also applies to accompanying drawings and diagrams. Due to a policy of continuous development Mors Smitt reserves the right to alter the equipment specification and description outlined in this datasheet without prior notice and no part of this publication shall be deemed to be part of any contract for the equipment unless specifically referred to as an inclusion within such contract. Mors Smitt does not warrant that any of the information contained herein is complete, accurate, free from potential errors, or fit for any particular purpose. Mors Smitt does not accept any responsibility arising from any party's use of the information in this document.