

## Modular Relays

### Auxiliary, Trip & Supervision Relays

- > Rugged modular construction
- > Rack or flush mounting
- > Range of function types
- > Draw out module
- > 5, 10 & 20 contact versions
- > Operating & reset coils are available for 24, 32, 48, 110, 125 or 250V DC nominal
- > High visibility electro-mechanical flag indication
- > Made in Australia



## Cross Reference List

		RMS	
		Pre-Defined	6R MATRIX
Alstom	Reyrolle	6RA	6RM
MVAJ	TR	6RJ	2HSM
MVAX	XR	6RX	1TM

## 6R MATRIX Pre-Defined versions

The 6R MATRIX series provides maximum flexibility which adds a degree of complexity to select and specify. A range of standard 'pre-defined' models have therefore been created to meet a wide range of standard requirements. Refer to:

- 6R MATRIX Pre-Defined relays.

## Additional Technical Data:

- 6R technical Data Supplement
- 6RM QUAD 4 Element Flag Relays
- M Series MATRIX Case System

The 6R MATRIX range has been developed to provide design engineers with a modular system of auxiliary relays to meet a wide variety of system configurations. Based on our well proven 6R heavy duty control relay, the 6R MATRIX system offers numerous benefits:

- Modular configuration to simplify panel layout & circuit design
- High packing density to reduce panel space requirements
- Standard component design to reduce delivery lead times
- Case suitable for both flush panel & 19 inch rack mounting
- Standard draw out module
- Heavy duty M4 screw terminals



Size 2M28-S



Size 4M56-S

## Specification Process

1. Select the functional elements required to meet system design requirements;
2. Complete the options section for each functional element & complete details;
3. Select case & accessories;
4. Group functional elements to fill cases such that panel space is minimized.

## Each 6R MATRIX relay is comprised of two main parts:

1. Outer casing
2. Functional element(s)

The completed relay is shipped from the factory fully assembled but for flexibility, each part is specified & numbered separately.

The main components & features are depicted below for a single element & a double element both mounted in a size 2 M Series case:

### One element per case

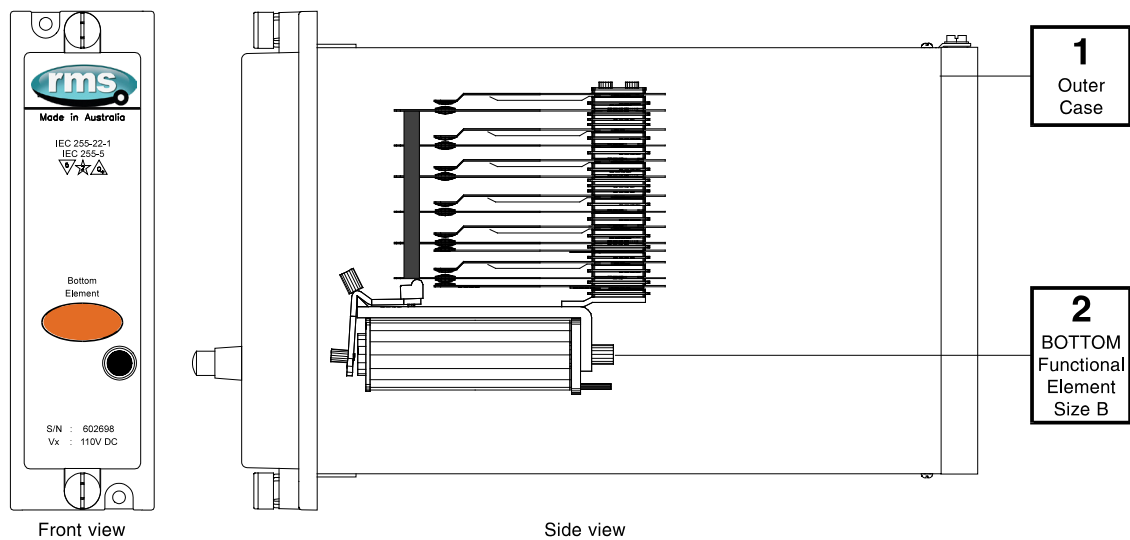

### Two elements per case

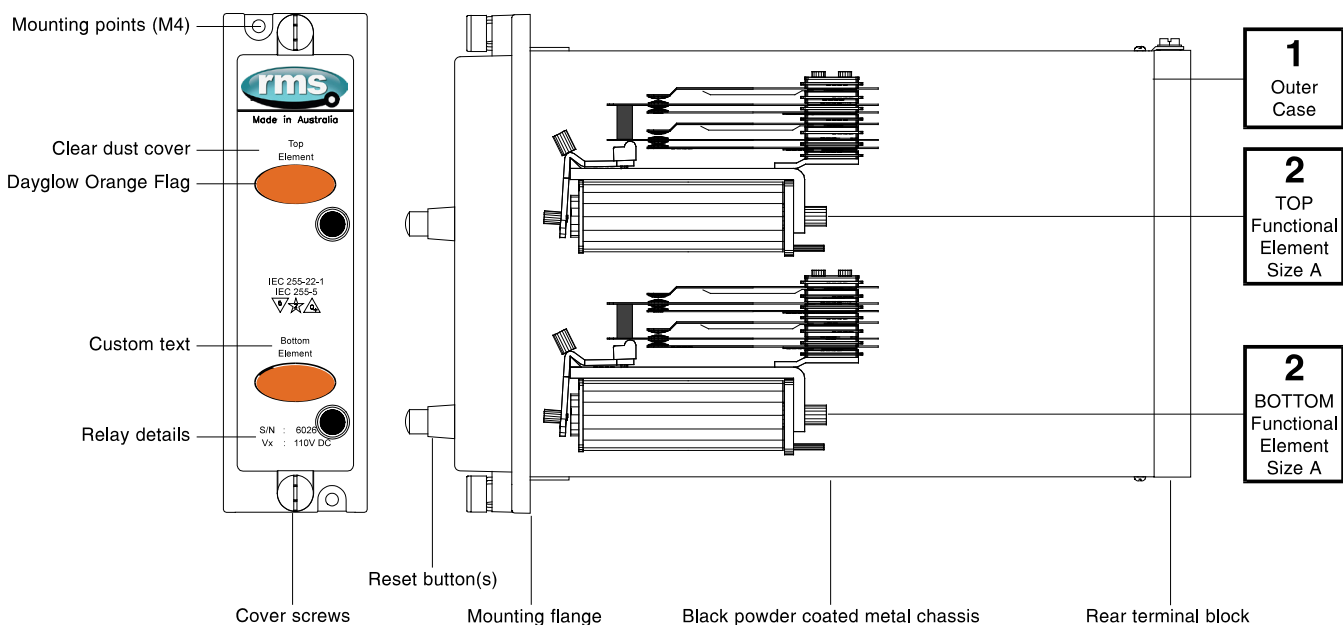

## Case Mounting

The following standard features are provided:

- Rack & flush mounting
- Draw out relay module
- Rear m4 screw terminals

## Case Construction

The outer case is manufactured from zinc coated mild steel providing considerable strength & black powder coated surface finish for corrosion protection. Relay elements are mounted on fabricated fiberglass & Acetal components to provide reliable electrical isolation & simple cost effective construction.

## Reset Buttons

Latching relays are provided with front mounted reset buttons.

## Flag Indicators

Each relay element is supplied with an operation (target) indicator. The indicator consists of a high visibility solid day glow orange mechanical flag which drops on energization or de-energization.

## Size 2M Case Fitment

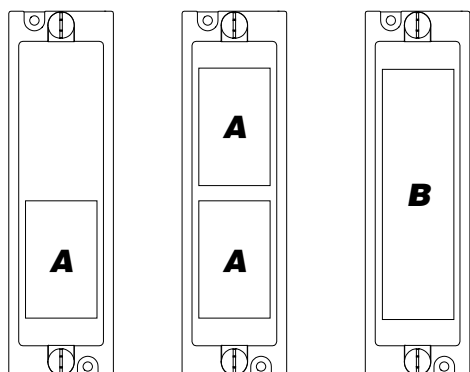

1 X A Element  
2M28-S-1 case

2 x A Element  
2M28-S-2 case

1 x B Element  
2M28-S-1 case

## Size 4M Case Element Fitment

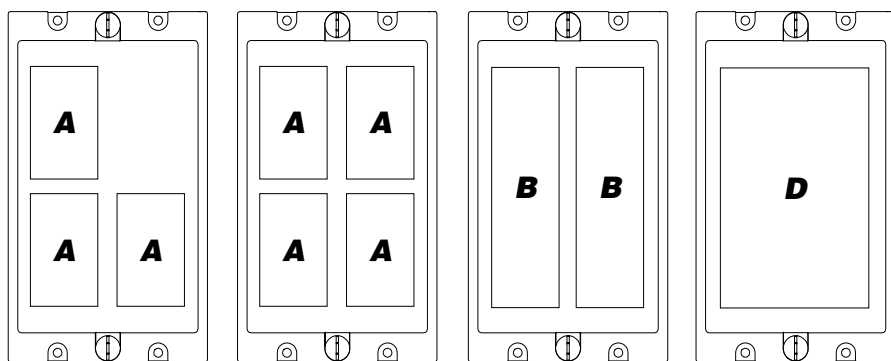

3 x A Element  
4M28-S-3 or  
4M56-S-3 case

4 x A Element  
4M28-S-4 or  
4M56-S-4 case

2 x B Element  
4M28-S-2 or  
4M56-S-2 case

1 x D Element  
4M28-S-1 or  
4M56-S-1 case

## Terminal Blocks

High quality moulded terminal block(s) are utilized. The draw out function is made possible through the use of inner & outer terminal blocks, each with silver plated contact fingers to provide high current rating & very low electrical resistance.

M4 screw terminals allow 2x crimp lug connections per point. Space efficient design allows 28 contact points per terminal block.

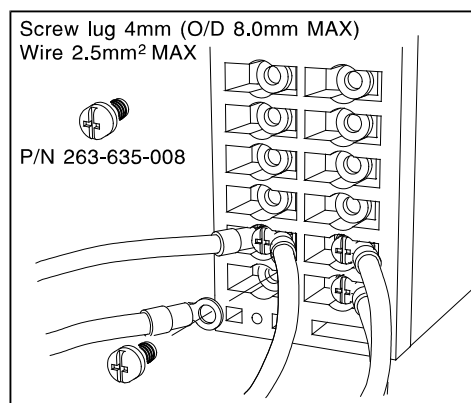

## Application

The effect of a fault on a power system is dependent on the speed with which the fault can be detected & isolated. The 2HS Series multi-contact high-speed trip relays are used for this isolating function providing simultaneous tripping outputs.

The operating element for the 6R MATRIX High Speed Trip functional elements are designated 2HSM. A high speed coil provides fast operation (<10ms at nominal DC operating voltage), with specially constructed anti bounce buffers ensuring effective damping of the contacts to avoid excessive bounce.

The Type 2HSM relays may be broadly divided into two groups:

- Low burden tripping relays
- High burden tripping relays

High burden tripping relays are designed to withstand the 10uF capacitor discharge test such that the relay will not operate when a 10uF capacitor charged to 120% of nominal operating voltage is applied across the coil of the relay.

## Low Burden Trip Relays

2HSM 502, 503, 504, 506, 507, 508, 509

These are low burden versions of types 2HSM relays respectively & are suitable for applications where immunity to capacitance discharge & high minimum operation currents are not required.

Circuit diagrams for types 2HSM504, 506, 508, 509 are as per 2HSM514, 516, 518, 519 without C1, R1 or R2 loaded. Circuit diagrams for types 2HSM503 are as per 2HSM502 without the flag.

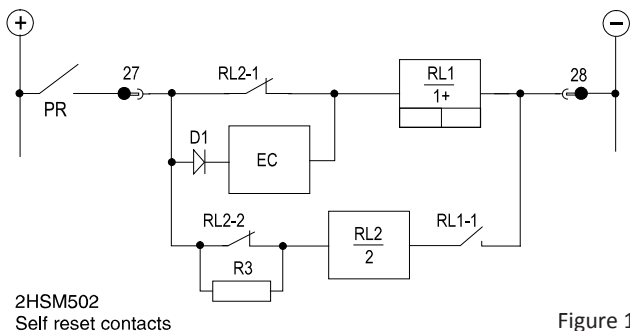

## High Burden Trip Relays

These relays are suitable for application in high security circuit breaker tripping circuits & in particular where the initiating contact may be remote from the relay. The high burden may also allow the satisfactory operation of external series elements.

These relays have a high burden to provide immunity to capacitance discharge currents & power to the coil is cut off at operation or is economized to a low figure to provide thermal protection.

## Operation of Series Elements

External relay elements are often employed for additional flagging & alarm functions. These elements are typically much slower than the primary high speed tripping relay so care must be taken to ensure reliable operation of the series element before the series trip signal is cut off or economized. In these circumstances a 2HSM relay with a time delayed (TD) cut off should be employed.

## High burden self-resetting type 2HSM 511, 512, 513, 520

This type uses a contact on the main contact stack (RL1-1), to energize a separate economizing element. After operation this reduces the burden by switching a second coil in series with the main element. The 2HSM520 version has a "slug" delay relay element fitted to provide time for series relays to operate.

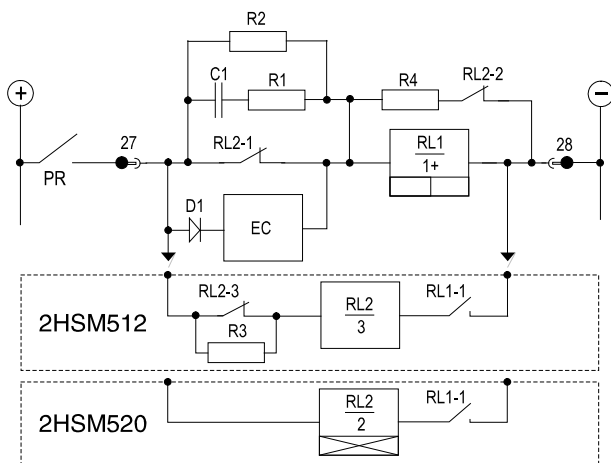

Figure 2

## Relays with time delayed cut off 2HSM 521, 522, 524, 525, 526

(See also 2HSM520)

These relays have time delayed cut off circuits such that the burden is reduced to zero 40 to 100ms), after energization by the use of a second attracted armature "slug" delay element. This delay allows ample time for any flagging or auxiliary elements in series with the tripping relay to operate before cut off. Contact RL1-1 is fitted to ensure the latching contacts & flag cannot be reset until the initiate voltage has been removed. The 2HSM521 is a special version requiring an auxiliary supply to provide a 2s delay on drop off.

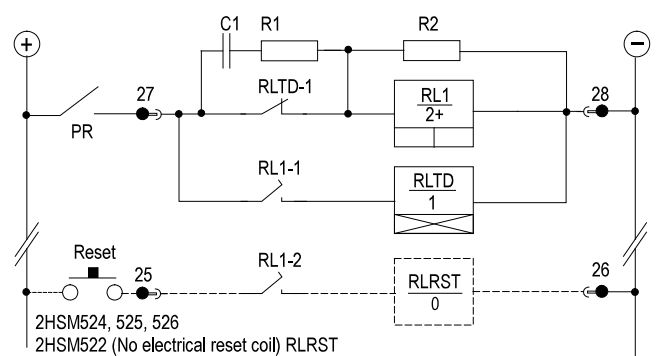

Figure 4

## High burden latching type with inst. cut off 2HSM 514, 516, 517, 518, 519

These relays incorporate a break contact (RL1-b), in series with the operate coil. Located below the main contact stack, it is arranged to break the coil circuit once the relay mechanism has completely operated. This reduces the relay burden to zero when the mechanical latching of the contact has occurred. An arc suppression circuit (R1 & C1), is used to protect RL1-b.

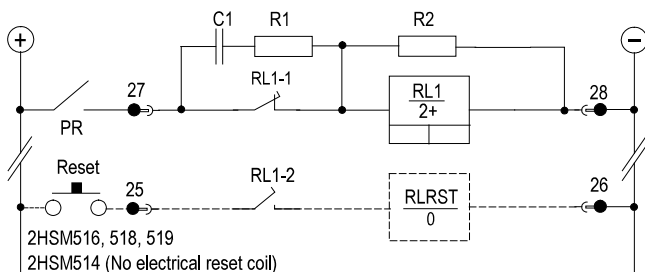

Figure 3

Relay Type	Contact		Flag	Cut off	Burden	Element Size	Minimum Case	Maximum Contacts	
	Refer note 1							Magnetic Blowouts	Heavy Duty
								M or B*	M or B*
								1	2
2HSM502	SR	HR		Econ.	Low	B	2M28-S1	9	13
2HSM503	SR	NF		Econ.	Low	B	2M28-S1	9	13
2HSM504		HR		Inst.	Low	B	2M28-S1	10	13
2HSM506	ER	HR		Inst.	Low	B	2M28-S1	9	12
2HSM507		ER		Inst.	Low	B	2M28-S1	9	12
2HSM508		H/ER		Inst.	Low	B	2M28-S1	9	12
2HSM509	H/ER	HR		Inst.	Low	B	2M28-S1	9	12
2HSM511	SR	SR		Econ.	High	B	2M28-S1	9	12
2HSM512	SR	HR		Econ.	High	B	2M28-S1	9	13
2HSM513	SR	NF		Econ.	High	B	2M28-S1	9	13
2HSM514		HR		Inst.	High	B	2M28-S1	10	13
					High	D	4M56-S1	20	20
2HSM516	ER	HR		Inst.	High	B	2M28-S1	9	12
					High	D	4M56-S1	19	19
2HSM517		ER		Inst.	High	B	2M28-S1	9	12
					High	D	4M56-S1	19	19
2HSM518		H/ER		Inst.	High	B	2M28-S1	9	12
					High	D	4M56-S1	19	19
2HSM519	H/ER	HR		Inst.	High	B	2M28-S1	9	12
					High	D	4M56-S1	19	19
2HSM520	SR	HR		TD	High	B	2M28-S1	5	8
				Econ.		D	4M28-S1	10	13
						D	4M56-S1	-	20
2HSM521	SR	HR		TD	High	B	2M28-S1	5	8
				Econ.		D	4M28-S1	10	13
						D	4M56-S1	-	20
2HSM522		HR		TD	High	B	2M28-S1	-	5
						D	4M28-S1	10	13
						D	4M56-S1	-	20
2HSM524	ER	HR		TD	High	B	2M28-S1	-	3
						D	4M28-S1	10	12
						D	4M56-S1	-	20
2HSM525		H/ER		TD	High	B	2M28-S1	-	3
						D	4M28-S1	10	12
						D	4M56-S1	-	20
2HSM526	H/ER	HR		TD	High	B	2M28-S1	-	3
						D	4M28-S1	10	12
						D	4M56-S1	-	20

Table 1

KEY: H/ER - Hand / electrical reset      SR - Self reset      HR - Hand reset  
 TD - Time delay 40 to 100ms      ER - Electrical reset      Econ. - Economy element  
 M - Make (N/O) contacts      B - Break (N/C) contacts      Inst. - Instantaneous cut off  
 Cont. - Continuously rated coil      C/F - Consult factory      NF - No flag

NOTES: 1. The Contact & Flag code should be read in conjunction with the section on flag & contact reset function on the following page.  
 2. C/O - Changeover contacts may be specified but each C/O contact replaces 1.5 M or B contacts.

EXAMPLE: 2HSM512-B2 represents a high burden high speed relay with a maximum of 9 M or 9 B (without magnetic blowouts), hand reset contacts and a self-reset flag. As the relay is an element size B, one of these elements may be fitted in a size 2M28-S1 case.



## Contact Bounce & Self Cleaning

Contact bounce occurs due to the speed at which the contacts meet. If too much coil power is used then the contacts will come together with too much force causing excessive bounce. It is therefore important to only fit relay coils with adequate power to provide the force required to switch the relay at the minimum operate voltage 65% of nominal.

In addition contact bounce can be greatly reduced through the addition of anti-bounce buffers. These components are added to each contact to provide a damping wiping motion when the contacts meet thus dissipating the force which would otherwise produce bounce.

Contacts are constructed from silver / copper alloy, shaped & positioned to ensure very reliable, low resistance operation. Over travel of the contacts during each operation causes a wiping action ensuring a clean "make".

The design of the contact surface is spherical such that when the contacts are driven to an over travel position they actually wipe. This wiping motion is part of the damping action mentioned above but also provides a wiping action which serves to clean the contact area.

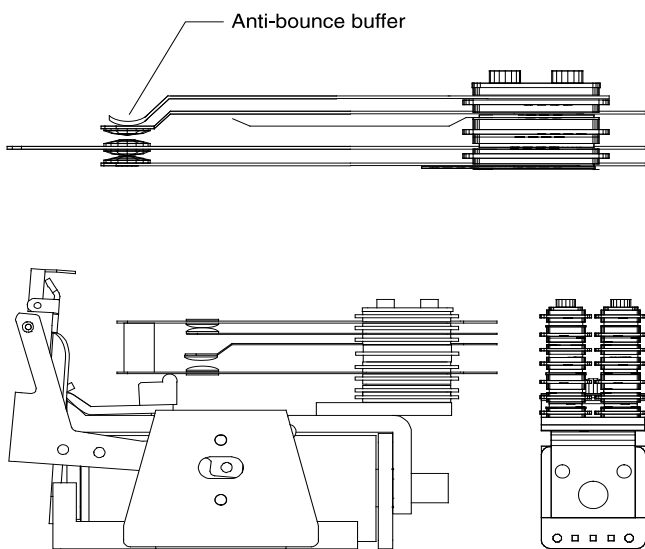

Figure 5

## Contact Stack Arrangement

The number of contacts indicated in Table 1 are the maximums that can be fitted for the element size. Fewer contacts may be specified to save cost. The operate time for relay elements with 14 to 20 contacts is <12ms at nominal operate voltage.

## Mixed Contacts Stacks

Mixed M & B contact arrangements may be specified provided the total number does not exceed the maximum indicated in table 1 for the relay element size specified above. Changeover contacts (C/O), are also available but must be counted as 1.5 M or B contacts & the result rounded down to the nearest integer & not exceed the maximum indicated in table 1.

## Flag & Contact Reset Function

### Combined operation & combined reset

Types: 2HSM504, 507, 508, 514, 517, 518, 522, 525

With these types the flag & contacts operate & reset together. I.e.

When the relay is tripped the flag changes state & the contacts latch. Both the flag & contacts are reset if either the reset button is pressed or the electrical reset coil is energized.

### Combined operation & independent reset

Types: 2HSM502, 506, 509, 512, 516, 519, 520, 521, 524, 526

With these types the flag & contacts operate together but may be reset independently. I.e. When the relay is tripped the flag changes state & the contacts latch. The contacts only are reset if the electrical reset coil is energized or the contact reset button is pressed. In both cases the flag is not reset. The flag can only be reset if the independent flag reset button is pressed.

## Flag Indicators

Each relay element is supplied with an operation (target) indicator. The indicator consists of a high visibility solid day glow orange mechanical flag which drops on energization (Type 2F).



## Operating Burden

Low burden relays	50W Maximum
High burden relays	150W Maximum
Reset Coils	40W Maximum

## Operated Burden

Self reset contacts	5W Maximum
Latching relays:	Zero
Reset coils:	Zero
Add 2 Watts for relays fitted with time delayed cut-off contact.	

## Coil Thermal Rating

Operating Circuit	Withstand continuous application of 120% nominal voltage
Coil Element (150 watt Max)	30 Secs

## Operating Time

<10ms at nominal operating voltage: <14 contacts
<12ms at nominal rated operating voltage: 14 - 20 contacts

## Operating Voltage Range

Between 65% and 120% of nominal rated operating voltage
---------------------------------------------------------

## Minimum Operating Current

Low Burden Relays	50mA
High Burden Relays	100mA

## Contact Ratings

Operating Voltage	Voltage free				
Isolation across open contacts	1 kV rms				
Make and carry: Continuous	3,000 VA AC resistive 3,000 W DC resistive maximums of 660V & 12A				
Make and carry for 3s	7,500 VA AC resistive 7,500 W DC resistive maximums of 660V & 30A				
AC break capacity	3,000 VA AC resistive with maximums of 660V & 12A				
DC break capacity					
Voltage		24V	48V	125V	300V
Resistive Rating	1	12	12	10	5
	2	12	2	0.8	0.3
Inductive Rating L/R=40ms	1	30	15	5.5	3.5
	2	12	1	0.35	0.15
1K operations (N3 Rating)	1	12	12	5	2.5

1 = With magnetic blowouts

2 = Without magnetic blowouts

## Magnetic Blowouts

Heavy duty contacts may be optionally fitted with magnetic blowouts to further increase the DC breaking capacity. This feature is particularly useful for breaking highly inductive loads such as that presented by high voltage circuit breaker trip coils. Refer to the 6R Technical Data Supplement for details.

## Wiring Diagram Example

6R MATRIX relays have custom wiring determined by the number & configuration of the contacts. To convey this information a label is attached to the internal side plate depicting the wiring information. As this stays with the product (unlike the paper wiring diagram also supplied), it cannot be lost.

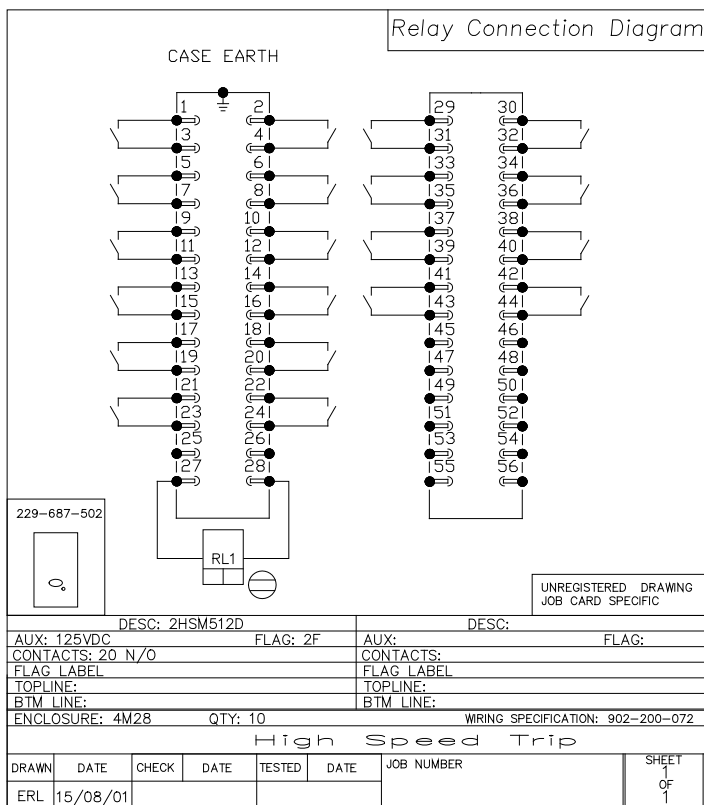

## Contact Operation

Self reset contacts. N/O contacts pick up when the relay is energised & drop out when the operate voltage is removed.

## Flag Operation

Drops on coil energisation.

Hand reset when the contacts are in the reset position.

## AC Voltages

Standard 6RJ relays are not intended for operation with AC voltages. Application of continuous AC voltage below the pick up level will cause excessive power dissipation in the capacitor discharge resistor & likely result in thermal damage to the device.

## Contacts

20 contacts

User to specify combination of make & break contacts

## Electrical Reset Mechanism

Operate voltage: As per specified operate voltage.

Reset cut off: Instantaneous with main relay reset.

Continuous application of both the high speed pick up coil & the reset coil (or contact reset button), will defeat the cut throat contact & result in overheating & thermal damage to both coils & associated circuit.

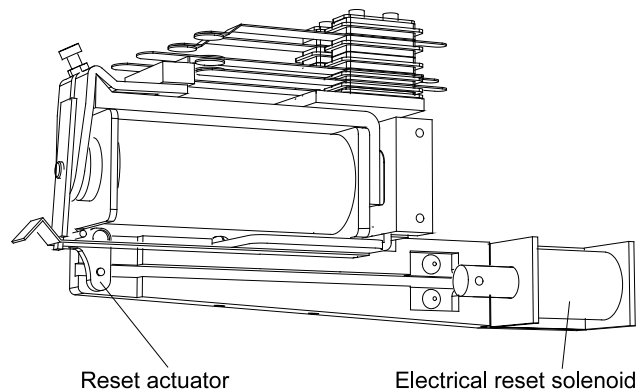
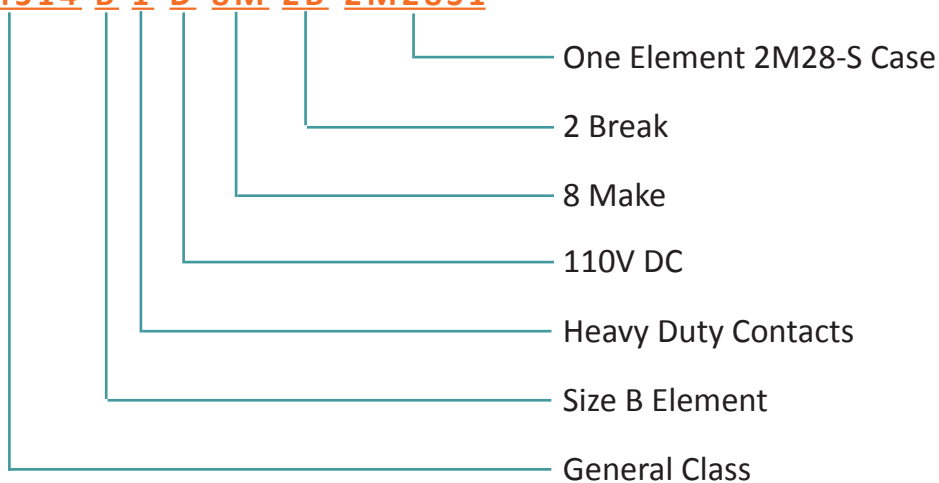

Figure 6

## Relay Order Code

2HSM						
Relay Function						Specify relay functional number from table 1.
Element Size	B					Size B Up to 1 element in a 2M case
	D					Size D Up to 1 element in a 4M case
Contact Duty		1				Heavy duty contacts – magnetic blowouts fitted
		2				Heavy duty contacts
Nominal Operate Voltage			A			24V DC
			B			32V DC
			C			48V DC
			D			110V DC
			E			125V DC
			F			250V DC
			G			220V DC
			H			240V DC
			L			110V AC
			N			220V AC
			P			240V AC
Contact Arrangement				0 M		Specify the number of "MAKES" followed by M
				0 B		Specify the number of "BREAKS" followed by B
Case Configuration					-	Element only – No case
					2M28-S1	One element in a 2M28-S case
					4M28-S1	One element in a 4M28-S case
					4M56-S1	One element in a 4M56-S case

Example Ordering Code: **2HSM514 B 1-D-8M 2B-2M28S1**



## Application

The operating element for the 6R MATRIX Auxiliary Relay functional elements are designated 6RM & are based on our 6R Series relays.

The type 6RM Series elements are low burden auxiliary relays which can be used where a scheme demands several contacts for event recording, alarm initiation, contact logic arrangements, etc.

The relay can be supplied fitted with heavy duty contacts & with heavy duty magnetic blow-outs fitted.

Contacts are constructed from silver / copper alloy, shaped & positioned to ensure very reliable, low resistance operation. Over travel of the contacts during each operation causes a wiping action ensuring a clean "make".

Heavy duty make, break & changeover contacts & heavy duty contacts fitted with magnetic blow-outs are available in various combinations. See table 2 below.

Heavy duty contacts fitted with magnetic blow-out are recommended for breaking heavy or highly inductive DC loads. When these are fitted, the number of contacts available may be reduced.

## Flag Indicators

Each relay element is supplied with a flag (target) indicator. The indicator consists of a high visibility solid dayglow orange mechanical flag which drops on energization or de-energization.

## Resets

Resetting of flags & contacts may be either manual at the relay panel or electrical via a remote signal or both. The provision to separately reset the flag & contacts is also possible.

## Electrical Reset Function

Combined contact / flag operation & reset 6RM210

With these types the flag & contacts operate & reset together. i.e.

When the relay is operated the flag changes state & the contacts latch. Both the flag & contacts are reset if either the reset button is pressed or the electrical reset coil is energized.

Combined Contact / Flag Operation  
& Independent Reset 6RM211

With these types the flag & contacts operate together but may be reset independently. I.e.

When the relay is operated the flag changes state & the contacts latch. The contacts only are reset if the electrical reset coil is energized or the contact reset button is pressed. In both cases the flag is not reset.

The flag can only be reset if the independent flag reset button is pressed.

## Coil Operating Power

Relay elements may be specified with 1W or 2W operating power for relay elements with up to 9 contacts. 2W coils have the advantage of faster operation for armature operated contacts but obviously generate more heat when continuously energized.

A second advantage which is particularly useful in high humidity climate installations is that the thicker gauge copper wire used in 2W coils is less susceptible to corrosion & going open circuit.

Relay elements with 10-20 contacts are fitted with a 5W nominal coil.

6R Element Part Numbers Timing Function									Maximum Contacts	
No Time Delay	Delay Release	Delay Operate	Contact	Flag	Element Size	Minimum Case	M or B*	M or B*		
							1	2		
6RM201	6RM301	6RM401	SR	NF	A	2M28-S1	4	6		
					B	2M28-S1	10	13		
					D	4M56-S1	20	20		
6RM202	6RM302	6RM402	SR	HR	A	2M28-S1	4	6		
					B	2M28-S1	10	13		
					D	4M56-S1	20	20		
6RM203	6RM303	6RM403			A	2M28-S1	4	6		
					B	2M28-S1	10	13		
					D	4M56-S1	20	20		
6RM204	6RM304	6RM404	H/SR	HR	A	2M28-S1	1SR / 1HR	2SR / 2HR		
					D	4M28-S1	2SR / 2HR	4SR / 4HR		
6RM206	-	6RM406		HR	A	2M28-S1	4	6		
					B	2M28-S1	10	13		
					D	4M56-S1	20	20		
6RM207	-	6RM407		ER	A	2M28-S1	1	2		
					B	2M28-S1	9	12		
					D	4M56-S1	19	19		
6RM208	-	6RM408	ER	HR	B	2M28-S1	9	12		
					D	4M56-S1	19	19		
6RM210	-	6RM410		H/ER	A	4M28-S1	1	2		
					B	2M28-S1	9	12		
					D	4M56-S1	19	19		
6RM211	-	6RM411	H/ER	HR	B	2M28-S1	9	12		
					D	4M56-S1	19	19		

Table 2

**KEY:** H/ER - Hand / electrical reset      SR - Self reset      HR - Hand reset  
H/SR - Hand / self reset      ER - Electrical reset      C/F-Consult  
factory  
M - Make (N/O) contacts      B - Break (N/C) contacts      NF - No flag

\*C/O - Changeover contacts may be specified but EACH C/O contact replaces 1.5 M or B contacts.

**EXAMPLE:** 6RM206-A1 represents an auxiliary relay with a maximum of 4 heavy duty M or B (Magnetic blowouts fitted), hand reset contacts.

As the relay element is a size A, two of these elements may be fitted in a size 2M28-S2 case.

## Number Of Output Relay Contacts

The number of contacts & configuration are specified in table 2. The number of enclosure terminals available is the limiting factor necessitating some contacts to be connected to a common circuit.

## Operating Times

Instantaneous Operating Times (6RM2xx Series)

Contact Stack	Pick up* 1W coil	Pick up* 2W coil	Drop out* 1W coil	Drop out* 2W coil
1 N/O	25	22	34	35
2 N/O	32	25	24	25
3 N/O	35	25	18	19
4 N/O	40	30	14	15
6 N/O	50	35	12	13
9 N/O	65	45	10	11
1 N/C	25	22	38	38
2 N/C	40	25	25	26
3 N/C	52	35	20	21
4 N/C	62	40	18	19
6 N/C	70	52	13	14
1 C/O	35	22	26	27
2 C/O	45	25	20	21
3 C/O	60	40	13	14
4 C/O	75	45	12	13
6 C/O	90	50	10	11
7 C/O	110	55	9	10

Table 3

Notes on Operating Times:

1. Tolerance on stated operate times: +/-10%
2. Operate times are in ms & refer to armature operated contacts at nominal stated coil operating voltage.
3. For flag operated contacts operate time is typically 60ms & is independent of the coil power.
4. 1W nominal coils are used as the default coil specification up to 9 N/O contacts. 5W coils are used for 10 to 20 contacts.

## Operating Times With Time Delay Slugs Fitted

Delay on drop off heel end slugs HES

Heel end slugs can be specified to provide delayed drop out times of up to 300ms. The more contacts specified the faster the drop out time.

Delay on pick up armature end slugs AES

Armature end slugs can be specified to provide delayed pick up times of up to 150ms. The more contacts specified the slower the pick up time.

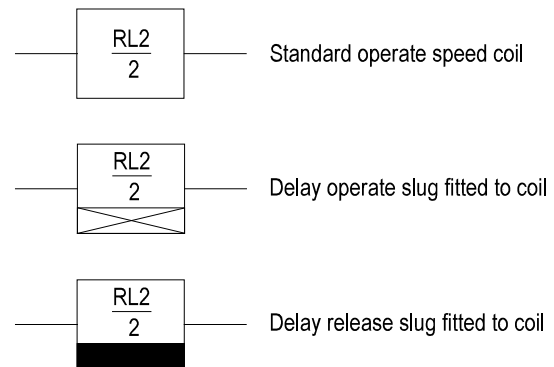

Figure 7

## Operating Burden

Operate coils	1 or 2W Up to 9 contacts
	5W 10-20 contacts
Reset Coils	40W Maximum

## Operated Burden

Self reset contacts	5W Maximum
Latching relays:	1W*
Reset coils:	Zero

\*Where a zero operated burden is required a break contact should be wired in series with the relay operate circuit.

## Coil Thermal Rating

Operating Circuit	Withstand continuous application of 120% nominal voltage
-------------------	----------------------------------------------------------

## Operating Time

<10ms at nominal operating voltage: <14 contacts
<12ms at nominal rated operating voltage: 14 - 20 contacts

## Operating Voltage Range

75% to 120% of nominal rated DC operating voltage
---------------------------------------------------

## Electrical Reset

Operate voltage	As per specified operate voltage.
Reset cut off	Instantaneous with main relay reset

Continuous application of both the operate coil & the reset coil will & result in overheating & thermal damage to the reset coil.

## Contact Ratings

Operating Voltage	Voltage free				
Isolation across open contacts	1 kV rms				
Make and carry: Continuous	3,000 VA AC resistive 3,000 W DC resistive maximums of 660V & 12A				
Make and carry for 3s	7,500 VA AC resistive 7,500 W DC resistive maximums of 660V & 30A				
AC break capacity	3,000 VA AC resistive with maximums of 660V & 12A				
DC break capacity					
Voltage	24V	48V	125V	300V	
Resistive Rating	1	12	12	10	5
	2	12	2	0.8	0.3
Inductive Rating L/R=40ms	1	30	15	5.5	3.5
	2	12	1	0.35	0.15
1K operations (N3 Rating)	1	12	12	5	2.5

1 = With magnetic blowouts

2 = Without magnetic blowouts



## Relay Order Code

6RM								
Relay Function								Specify relay functional number from table .
Element Size	A							Size A Up to 2 elements in a 2M case
	B							Size B Up to 1 element in a 2M case
	D							Size D Up to 1 element in a 4M case
Contact Duty		1						Heavy duty contacts – magnetic blowouts fitted
		2						Heavy duty contacts
Nominal Operate Voltage			A					24V DC
			B					32V DC
			C					48V DC
			D					110V DC
			E					125V DC
			F					250V DC
			G					220V DC
			H					240V DC
			K					60V AC
			L					110V AC
			N					220V AC
			P					240V AC
	Contact Arrangement				0 M			
				0 B				Specify the number of "BREAKS" followed by B
				0 C				Specify the number of "CHANGEOVER" followed by C
Flag Operation					-			No flag
					A			Flag drops on energization (Factory default)
					B			Flag drops on de-energization
Operating Time						A		1W operating coil (5W for 10-20 contacts)
						B		2W operating coil
Case Configuration							-	Element only – No case
							2M28-S1	One element in a 2M28-S case
							2M28-S2	Two identical elements in a 2M28-S case
							4M28-S2	Two identical elements in a 4M28-S case
							4M28-S3	Three identical elements in a 4M28-S case
							4M28-S4	Four identical elements in a 4M28-S case
							4M56-S1	One element in a 4M56-S case
							4M56-S2	Two identical elements in a 4M56-S case
							4M56-S3	Three identical elements in a 4M56-S case
							4M56-S4	Four identical elements in a 4M56-S case

Example Ordering Code: **6RM202B1-D-8M2B-AA-4M28S2**

## Application

The 1TM Series Relays provide fail safe supervision of CB trip circuits. Three models are available depending on the degree of supervision required & wiring configuration.

Supervision	6R MATRIX Element			
	1TM10	1TM11	1TM12	1TM13
CB 52a contact	Yes	No	Yes	No
CB 52b contact	Yes	No	Yes	No
Trip supply	Yes	Yes	Yes	Yes
Trip coil continuity	Yes	No	Yes	No
Trip wiring continuity	Yes	No	Yes	No
Trip relay circuit	No	No	No	Yes

Table 4

The relay can be supplied fitted with heavy duty contacts & with magnetic blow-out fitted.

A significant safety feature is the fitting of internal resistors to limit the trip coil current to well below the circuit breaker trip coil operate current, should the relay be accidentally short circuited.

## Standard supervision relays available

Relay Type	Function	Flag	Element Size	Case	Alarm Contacts
1TM10	Trip Circuit Supervision	Hand reset	B	2M28-S1	2 C/O
1TM11	Trip Supply Supervision	Hand reset	B	2M28-S1	2 C/O
1TM12	Trip Circuit Supervision	Hand reset	D	4M28-S1	2 C/O
1TM13	Trip Relay Supervision	Hand reset	B	2M28-S1	2 C/O

Table 5

## Flag operation

Each relay element is supplied with a flag (target) indicator. The indicator consists of a high visibility solid dayglow orange mechanical flag.

Operation: Drops on coil de-energization.  
Reset: Hand reset.

## Thermal Rating

All 1TM relay element circuits are designed to withstand continuous application of 120% of nominal voltage.

## 6R relay contact ratings

Refer 6RM data.

## Insulation Withstand

In accordance with IEC 255-5:

2KV RMS & 1.2/50 5KV impulse between:

- all input terminals & frame
- all output terminals & frame
- all input & output terminals
- each input group
- each output group

## 1TM10 Trip Circuit Supervision Relay

The operating element of the 1TM10 comprises a single 6R heavy duty attracted armature control relay with two operating coils wound on a single core.

Supervision is active with the circuit breaker in the open or closed position via the 52a & b auxiliary contacts.

Under healthy conditions, with the CB in the closed position, winding 1 is energized & if the trip coil becomes open circuited or the supply fails, the relay will drop out initiating the local visual indicator & output contacts. Similarly, when the CB is in the open position, both coil windings 1 & 2 are energized enabling the relay to detect failure of the trip circuit coil or supply in the same manner as if closed. Once operated the electro-mechanical alarm flag must be hand reset.

The relay element is fitted with a slug to provide a delay of 300ms (approx.) on de-energization preventing a false alarm due to voltage dips in the supply rail, or the normal delays in the tripping operation, when the first coil winding is momentarily short circuited by the protection trip contact. If the protection trip contact should fail to reset, due to a failure of the circuit breaker tripping mechanism for example, the relay drops out initiating the local visual alarm indicator & output contacts.

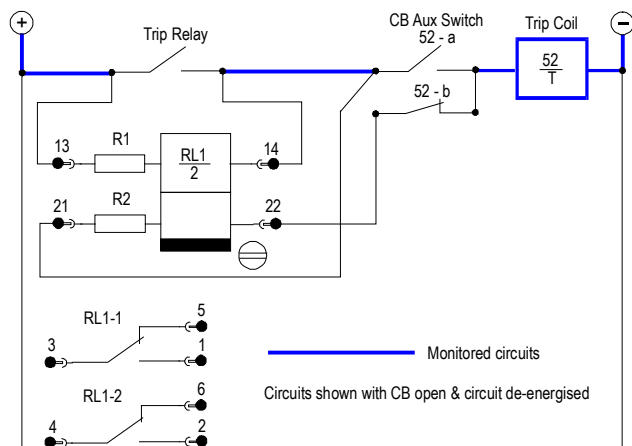

Figure 8

## Circuit Resistance and Burden

The 1TM10 circuit design is optimized to minimize the supervision current in the CB trip coil to avoid the possibility of nuisance tripping. The total series resistance provided by R1 & RL1 - winding 1 is tabulated below. Resistance of the CB coil must be much less than this figure to ensure adequate supervision current flows through the 1TM10 element under normal conditions.

Nominal supply	~Resistance (ohms)	Current (mA)	Burden* (Watts)
32V DC	2,200	15	<0.5
48V DC	3,100	15	<0.8
110V DC	7,400	15	<1.7
125V DC	7,400	17	<2.2
220V DC	25,000	9	<2.0
240V DC	25,000	10	<2.4
250V DC	25,000	10	<2.5

Table 6

## Trip Supply Burden

\* Actual operating burden is dependent on the CB coil resistance.

## Operating Voltage Range

Guaranteed operation between 80% & 120% of nominal rated operating voltage.

## 1TM11 Trip Circuit Supply Supervision

The operating element of the 1TM11 comprises a single 6R heavy-duty attracted armature control relay with a single operating coil & delay slug. The relay is normally operated to indicate a healthy trip circuit supply while a slug is fitted to provide a delay on drop out & avoid nuisance tripping due to transients.

Under healthy conditions the coil is energized & if the supply fails, the relay will drop out after a short time delay (200ms approx.), to initiate a supply fail alarm.

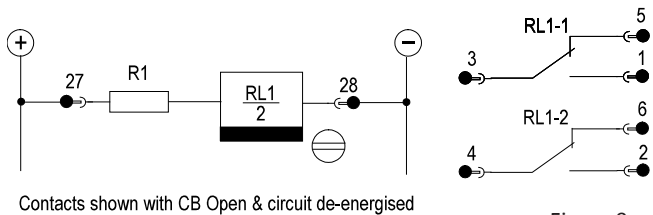

Figure 9

## Flag Operation

Each relay element is supplied with a flag (target) indicator. The indicator consists of a high visibility solid dayglow orange mechanical flag.

Operation: Drops on coil de-energization.

Reset: Hand reset.

## Drop Out Voltage

Drop out >15% of nominal rated operate voltage.

## Reset Time

Not less than 300ms when supply is switched from 100% of nominal rated operating voltage to off.

## Nominal Operating Voltages

24, 32, 48, 110, 125, 220, 240 & 250V DC available.

## Contacts

2 C/O standard

## Circuit Resistance & Burden

The 1TM11 circuit design is optimized to minimize the supervision current to minimize the burden on the supervised supply. The total series resistance provided by R1 & RL1 is tabulated below.

Nominal supply	~Resistance (ohms)	Current (mA)	Burden (Watts)
24V DC	1,200	20	<0.6
32V DC	1,600	20	<1.0
48V DC	2,400	20	<1.0
110V DC	11,000	10	<1.2
125V DC	11,000	11	<1.5
220V DC	22,000	10	<2.5
240V DC	24,000	10	<2.5
250V DC	24,000	11	<2.7

Table 7

## Drop Out Voltage

Drop out between 25 & 40% of nominal rated operate voltage.

## Reset Time

Not less than 200ms when supply is switched from 100% of nominal rated operating voltage to off.

## 1TM12 Trip Circuit Supervision Relay

The operating element of the 1TM12 comprises three 6R heavy duty attracted armature relays as shown below.

Supervision is active with the circuit breaker in the open or closed position via the "a & b" CB auxiliary contacts.

Under healthy conditions, with the CB in the closed position, relay 1 & 2 are energized & if the trip coil becomes open circuited or the supply fails, relay 2 will drop out causing alarm relay 1 to drop out & initiate the local visual indicator & output contacts. Similarly, when the CB is in the open position, relays 1, 2 & 3 are energized enabling the relay to detect failure of the trip circuit coil or supply in the same manner as if closed. Once set the alarm relay flag must be hand reset.

If the protection trip contact operates alarm relay 1 will drop out after 300ms (approx.) unless the CB auxiliary contact opens within this time causing relay 3 to pick up. The 300ms delay prevents false alarms due to normal delays in the tripping operation.

Relay 1 element is fitted with a slug to provide a delay of 100ms (approx.) on de-energization to prevent false alarms due to voltage dips in the supply rail.

If the protection trip contact should fail to reset, due to a failure of the circuit breaker tripping mechanism for example, the relay drops out initiating the local visual alarm indicator & output contacts.

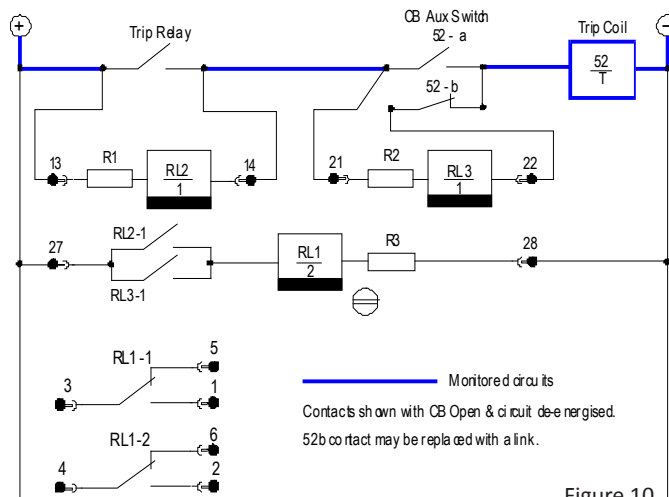

Figure 10

## Circuit Resistance & Burden

The 1TM12 circuit design is optimized to minimize the supervision current in the CB trip coil to avoid the possibility of nuisance tripping. The total series resistance provided by R1 & RL2 is tabulated below. Resistance of the CB coil must be much less than this figure to ensure adequate supervision current flows through the 1TM12 element under normal conditions.

Nominal supply	~Resistance (ohms)	Current (mA)	Burden* (Watts)
32V DC	1,090	30	<1.0
48V DC	1,600	20	<1.5
110V DC	8,100	14	<1.5
125V DC	8,100	15	<2.0
220V DC	25,000	9	<2.0
240V DC	25,000	10	<2.4
250V DC	25,000	10	<2.5

Table 8

## Trip supply burden

\* Actual operating burden is dependent on the cb coil resistance.

## Alarm circuit burden

Allow a nominal 1 watt for the alarm relay r11 which is normally energised under healthy trip circuit conditions.

## Operating voltage range

Guaranteed operation between 80% & 120% of nominal rated operating voltage.

## Drop out voltage

Drop out >15% of nominal rated operate voltage.

## Reset (drop out) delay

Not less than 100ms when supply is switched from 100% of nominal rated operating voltage to off. Not less than 300ms during trip circuit interruptions.

## Nominal operating voltages

24, 32, 48, 110, 125, 220, 240 & 250V dc available.

## Contacts

2 C/o standard

## 1TM13 Trip Relay Circuit Supervision

The 1TM13 relay is designed to supervise trip relay circuits utilizing high burden trip relays such as the 6RJ & 2HSM series available from RMS.

The operating element comprises a single 6R heavy-duty attracted armature control relay with a single operating coil & delay slug. It has two dropping resistors R1 & R2 of equal ohmic value, connected in series with the coil.

If the circuit being supervised becomes open circuited or if the supply fails, the relay will become reenergized and an alarm or visual indication will be given.

Under healthy conditions the relay coil is energized via the dropping resistor R1 as shown below (Tripping relay circuit). If the circuit being supervised becomes open circuit or if the supply fails, the relay will become de-energized & an alarm is given (2 C/O contacts & flag indication).

To prevent the alarm being given when the circuit being supervised is operated the relay coil is maintained via the dropping resistor R2. For this purpose, an additional normally open contact is required from the latching tripping relay as depicted at right. A short time delay (>100ms), is incorporated to hold up the alarm relay during a normal trip relay operation.

Contacts are constructed from silver, shaped & positioned to ensure reliable, low resistance operation. Over travel of the contacts during each operation causes a wiping action ensuring a clean "make".

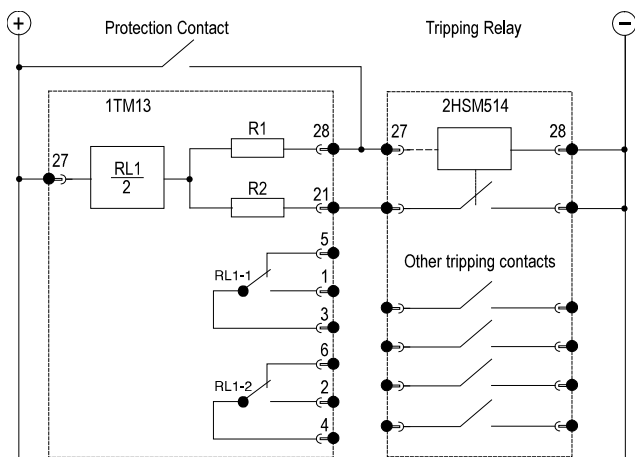

Figure 11

## Circuit Resistance & Burden

The 1TM13 circuit design is optimized to minimize the supervision current in the tripping relay coil to avoid the possibility of nuisance tripping. The total series resistance provided by the combination of RL1/R1 & RL1/R2 is tabulated below. Resistance of the CB coil must be much less than this figures to ensure adequate supervision current flows through the 1TM13 element under normal conditions.

Nominal supply	~Resistance (ohms)	Burden * (Watts)
32V DC	2,200	<0.6
48V DC	3,100	<0.9
110V DC	8,000	<1.7
125V DC	8,000	<2.2

Table 9

## Trip Supply Burden

\* Actual operating burden is dependent on the tripping relay coil resistance.

## Thermal Rating

All operate & reset circuits are designed to withstand continuous application of 120% of nominal voltage

## Operating Voltage Range

Guaranteed operation between 70% & 120% of nominal rated operating voltage.

## Drop Out Voltage

Drop out voltage: >10% of nominal rated operate voltage

## Relay Order Code

1TM-			
Relay Function			Specify relay functional number from table 5.
Nominal Operate Voltage	A		24V DC
	B		32V DC
	C		48V DC
	D		110V DC
	E		125V DC
	F		250V DC
	G		220V DC
	H		240V DC
	I		60V DC
Number of Contacts		1	Heavy duty contacts – magnetic blowouts fitted
		2	Heavy duty contacts
Contact Arrangement		-	Element only – No case
		2M28-S1	One element in a 2M28-S case
		4M28-S2	Two identical elements in a 4M28-S case

Example Ordering Code: **1TM10-D2-2M28S1**

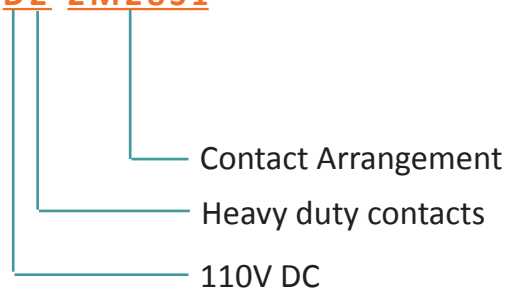



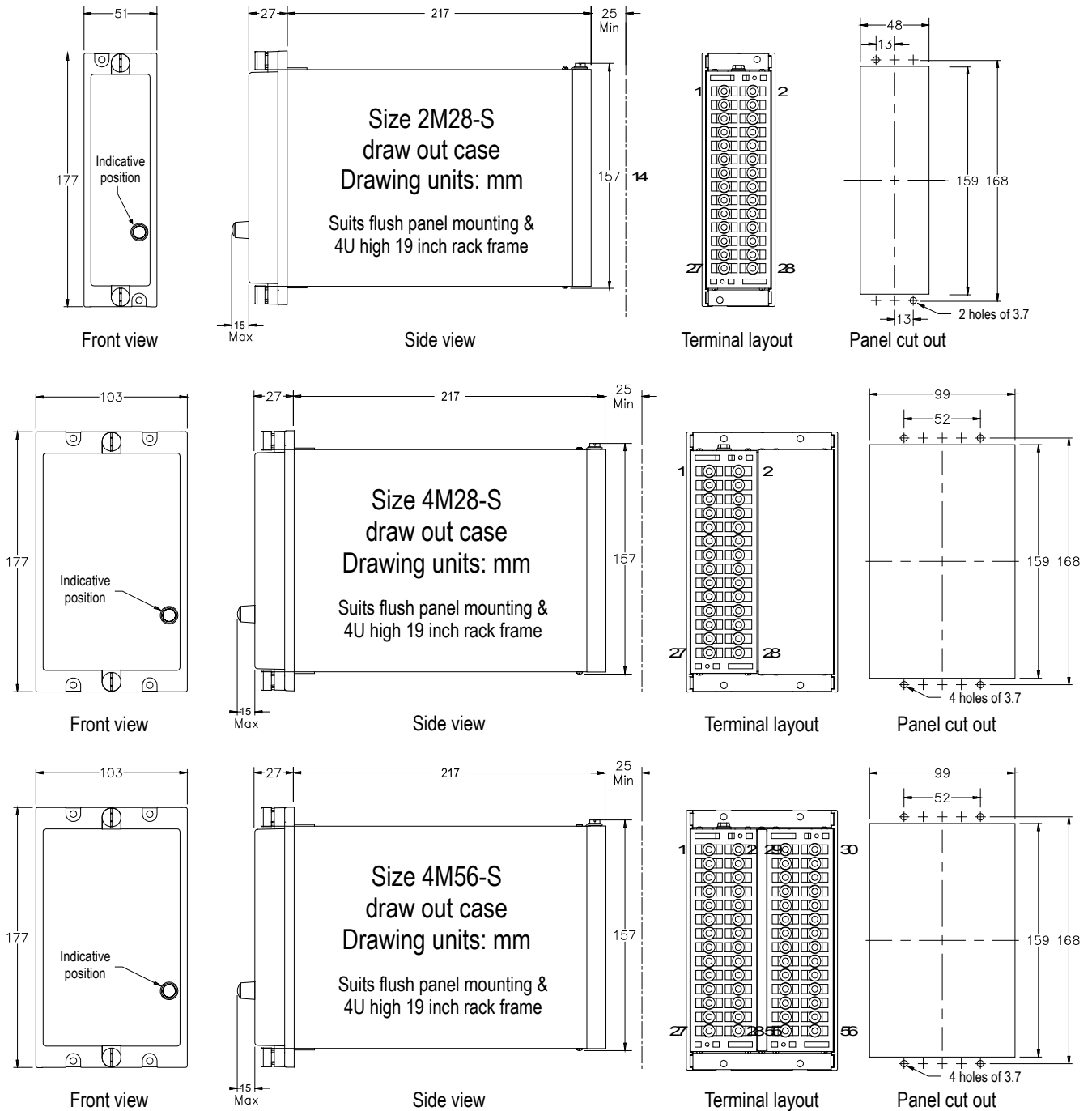

Figure 12

## Technical Data

Current Ratings	
CT terminals	20A continuous
	400A 1s
Other terminals	10A continuous
	200A 1s
Voltage Ratings	
All circuits & terminals:	600V AC continuous
	350V DC continuous

## Auxiliary Insulation Withstand

In accordance IEC 255-5:  
 2KV RMS between all terminals & all terminals & frame.  
 1.2/50 5KV impulse between all terminals & all terminals & frame.

## IP rating

IP5X category 2 dust protected and IP4X for solid ingress to IEC60529.

## M Series Case Accessories

Refer to the M Series Technical Bulletin:

<http://www.rmspl.com.au/mseries.htm>

- Sub rack mount frames
- Blanking plates
- Mounting screw kits
- Termination ring lugs
- Stud terminal kits
- Semi projection mount kits
- Earth bars

## M Series Case System

The M Series case range has been specifically designed to meet the demanding & varied requirements for applications in power utility sub-station environments. The standard 4U high 19 inch rack mounting modular configuration simplifies panel design & installation.

Mounting points & overall panel dimensions meet international standards such that the cases may be interchanged with other similar types available on the market.

The MATRIX-S version was released in mid August 2005 with the length reduced by 18mm to improve compatibility with shallow cubicles.

Care should be taken when ordering spare relay modules to ensure compatibility with existing units.

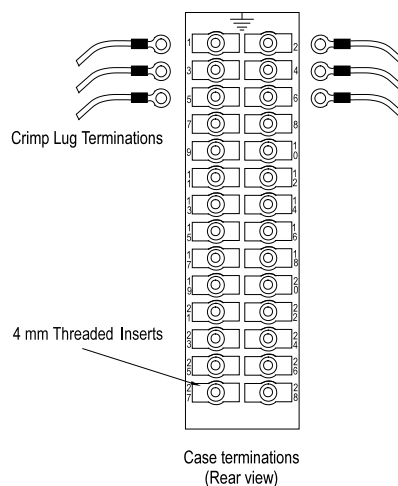

## Case Mounting Screws

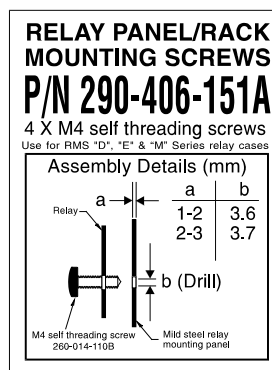

M Series cases may be flush mounted to mild steel panels up to 3mm thick using the M4 self threading screws provided with the case. Panel mounting is simplified due to the location of the fixing screws at the front face of the relay. Alternatively the cases may be 19 inch rack mounted using a 4U high sub rack. The M4 self threading screws are suitable for application with the RMS type 4M800K1 sub

# 6R MATRIX

## Relay Order Code

		M	-S	
Case Size	2			Size 2
	4			Size 4
Number of Terminals		28		Heavy duty contacts – magnetic blowouts fitted
		56		Heavy duty contacts
Relay Elements Per Case			1	One
			2	Two
			3	Three
			4	Four

Example Ordering Code: **2M28-S1**

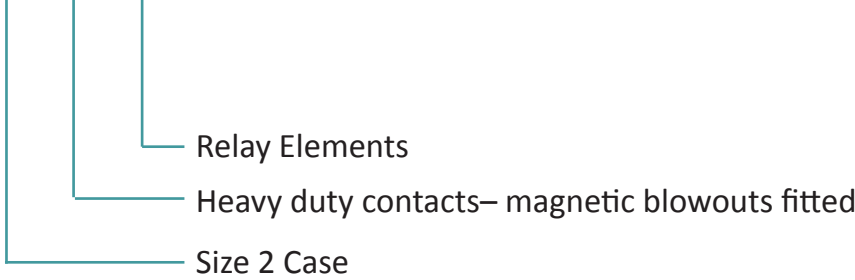



[www.relays.com.au](http://www.relays.com.au)



Relay Monitoring Systems Pty Ltd design, manufacture and market a wide range of electrical protection and control products for application on high voltage power systems. The company's depth of local manufacturing and engineering expertise is backed up by many years of experience since the formation of its predecessor, Relays Pty Ltd (RPL), in 1955. This experience combined with a broad base of field proven product types enables RMS to service specific customer needs by producing relays on demand with typically short lead times.

Relay Monitoring Systems Pty Ltd

6 Anzed Court  
Mulgrave, Victoria 3170 Australia  
Ph: +61 3 8544 1200  
Fax +61 3 8544 1201  
Email: [rms@rmspl.com.au](mailto:rms@rmspl.com.au)  
[www.rmspl.com.au](http://www.rmspl.com.au)  
[www.relays.com.au](http://www.relays.com.au)

#### **ISO9001 Quality Accreditation**

RMS holds BSI (British Standards Institute) registration number 6869 for the certification of a quality system to AS/NZS ISO9001:2008.

Due to RMS continuous product improvement policy the information contained in this document is subject to change without prior notice.  
2015 Relay Monitoring Systems Pty Ltd ABN 76 052 484 483