

# Delta XRD-8



AUXILIARY | TRIPPING | SUPERVISION

## Supervision Relay

The XRD-8 is a compact high-performance supervision relay for application with magnetic actuated circuit breakers.

- > Auxiliary supply supervision
- > Trip circuit supervision
- > Green Supervision Healthy LED
- > Self-reset red Supervision Fail LED
- > Two C/O alarm contacts
- > Surface or rail mount
- > Flush panel or rack mount
- > Made in Australia



## Application

The Delta XRD-8 has been designed to specifically operate with magnetic actuated circuit breaker control modules.

Supervision currents have been chosen to ensure reliable differentiation between supervised and tripped conditions.

A green Healthy LED is standard. Failure of the circuit or supply being supervised will cause the main relay element to drop out, an alarm signalled via the red LED and the alarm contacts to change state.

The Delta range is packaged in a size 2, 2U high case that may be flush panel, rack or rail mounted.

A plug in terminal block is provided to allow panel pre-wiring.

## Model Designation

DELTA XRD MODELS:

- > XRD-4 Trip supply supervision with hand-reset mechanical flag alarm indication
- > XRD-5 Trip supply supervision with self-reset LED alarm indication
- > XRD-6 Trip circuit supervision with hand reset mechanical flag alarm indication
- > XRD-7 Trip circuit supervision with self-reset LED alarm indication
- > XRD-8 Trip circuit supervision with self-reset LED alarm indication for application with magnetic actuated circuit breakers

## Note:

The Trip Circuit Supervision module is not designed to be used as a supply voltage monitor. The Actuator Coil is not monitored by the module only the Trip Control circuit.

## Features

- > High visibility red LED alarm indication
- > Supervision Healthy LED
- > Two C/O alarm contacts
- > Rated operate voltages available for 24, 30/32, 48, 110, 125, 220, 240 or 250 Volts DC nominal auxiliary supplies
- > Panel, rack or rail mount options
- > Compact size 2, 2U high case
- > Plug-in terminal block
- > M4 screw terminals

## Monitoring of Trip Control Circuit

As illustrated below in the typical scheme diagram, monitoring current is continually flowing in the trip circuit, being supplied from the +ve pin of the control module/relay. If any part of the circuit becomes open circuit then both sensing circuit outputs will go low, causing the TCS Healthy LED to turn OFF, initiate a Remote TCS Alarm after a 200mS delay.

The TCS1 sensing circuit continues to monitor the control circuit when a trip contact is closed but will turn off (after a 200mS Delay) if there is a break in the control circuit or loss of the Trip Control supply from the control module/relay. The TCS2 sensing circuit monitors the trip contacts and if closed TCS2 will turn off (after a 200mS Delay).

An alarm condition indicated by the TCS Healthy LED exists only when both are off caused by a failure of the trip circuit or loss of the Trip Control supply from the control module/relay.

The alarm condition is reset when the trip circuit is returned to its healthy state.

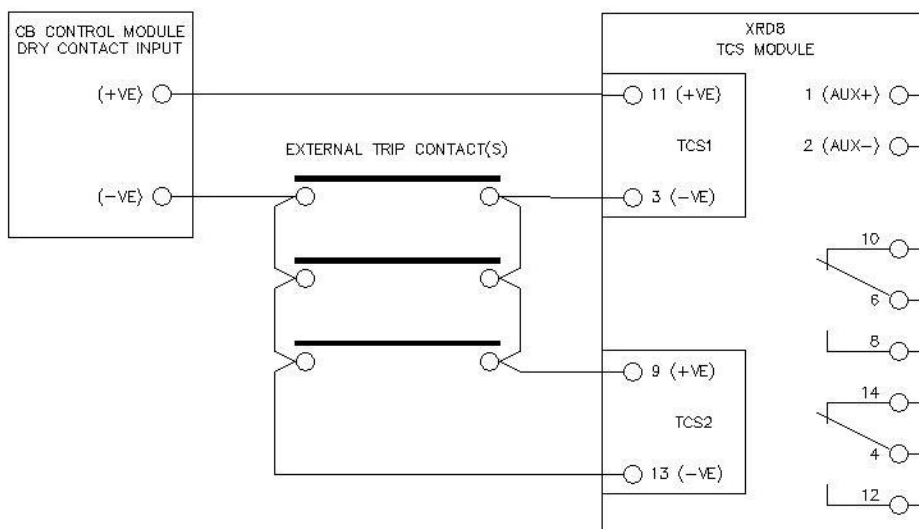

## Front Panel Layout

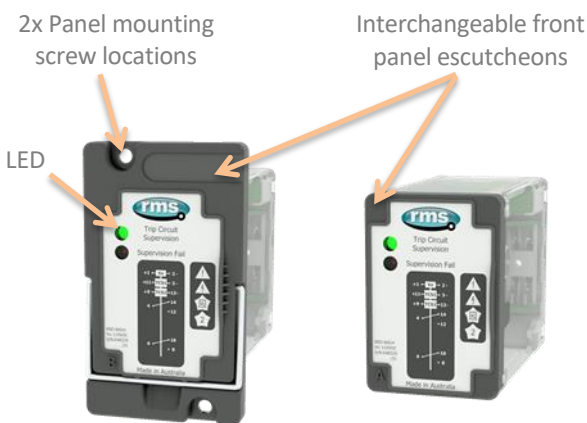

Figure: 1: XRD front panel  
Left – Panel mount      Right – rail mount

## Front Panel Configuration

Delta relays can be easily converted from a rail mount to a flush mount configuration. This is achieved by un-clipping the front rail mount escutcheon, securing a metal panel mount plate with four (4) screws and clipping on a panel mount escutcheon. This process may be reversed to convert from a panel mount to a rail mount version.

Delta relays may be ordered with the desired configuration or converted by the user using one of the conversion kits listed in the ordering section.



## Supervision Healthy LED

A front panel green LED is provided to indicate when the supervised circuit is HEALTHY.

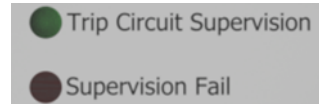

## Alarm Contacts

All contacts operate (Pick-up), when the monitored circuit is in the HEALTHY condition. FAILURE of the supervision circuit will cause the alarm contacts to drop out.

## Self-Reset Red LED Flag

A red LED flag is illuminated when the supervised circuit status changes from the HEALTHY to the FAIL condition. The flag will automatically extinguish after the supervision fail condition has been corrected.

## Nominal Auxiliary Voltages

24, 32, 48, 110, 125, 220, 240 and 250V DC available.

## Terminal Block

TBD-R1 /R2	Rear connect terminal block Suitable for flush mount relay version
TBD-F	Front connect terminal block Suitable for rail mount relay version

## Operating Voltage Range

70% to 120% of nominal continuous at 25 degrees Celsius

## Normal Operating Conditions

TRIP CIRCUIT AND AUXILIARY SUPPLY HEALTHY

Normal operating condition is indicated on the front panel via a green LED and the alarm contact being picked up.

## Abnormal Operating Condition

TRIP CIRCUIT FAIL – ALARM CONDITION

The green Trip Circuit Healthy LED is extinguished, the red Supervision Fail LED illuminated and the alarm contacts drop out. These conditions will self-reset after the supervision fail condition is corrected.

TRIP SUPPLY FAIL – ALARM CONDITION

The red Supervision Fail LED will also be extinguished when the auxiliary supply falls below 50% of nominal.

## Drop-out Voltage

The highest voltage level at which the relay will drop out and signal an alarm is 70% of nominal.

The lowest voltage level at which the relay will remain picked up is 35% of nominal. An alarm signal condition is output for input voltages below 35% of nominal.

## Drop-out Time

Trip circuit fail: 140-200 ms

Loss of supply: 200-400 ms

## Trip Supply Burden

The actual operating burden is dependent on the combined circuit breaker and CB trip circuit wiring.

## Alarm Circuit Burden

The maximum XRD-8 relay burdens are as follows.

Nominal	Healthy	Alarmed
24V	4.5W	0.3W
32V	5.0W	0.5W
48V	4.5W	0.75W
110V	4.5W	1.0W
125V	4.5W	1.0W
220V	5.5W	1.9W
240V	5.5W	2.0W
250V	5.5W	2.0W

## Alarm Signalling

- > 2 C/O alarm contacts
- > Self-reset red alarm LED

## Contact Ratings

Contact material	AgNi	
Maximum switching voltage	250 V / 440 V AC	
Minimum switching voltage	5 V	
Minimum switching current	5 mA	
Contact resistance	< 100 mΩ (initial)	
Rated Load (capacity)	AC1	8 A / 250 V AC
	DC1	8 A / 24 V DC
	AC15 (B300)	3 A/120 V 1.5 A/240 V
	AC3	550 W (single phase motor)
	DC13 (R300)	0.22 A/120 V 0.1 A/250 V
Max AC breaking capacity	2,000 VA	

## ATMOSPHERIC ENVIRONMENT

### Temperature

Standard	IEC 60068-2-1, IEC 60068-2-2	
Test Identification	Test specification	Auxiliary power Supply voltage
Operating Range	-10 to +55°C	Min and Max
Storage Range	-25 to +70°C	Non-energized
Test duration	16 hours at top and bottom temperatures	

### Damp Heat (Humidity)

Standard	IEC 680068-2-78 ENA TS 48-5, Issue 3, 2010	
Test Identification	Test specification	
Operating Range	40°C and 93% RH non- condensing	
Test duration	16 hours	

### IP Rating

Standard	IEC 60529 ENA TS 48-5, Issue 3, 2010	
Test Identification	Test specification	
Installed	IP5x	

## MECHANICAL ENVIRONMENT

### Vibration - Sinusoidal

Standard	IEC 60255-21-1 Class 1	
Test Identification	Test specification	Variation
Vibration Response in each of 3 axes	0.035 mm/0.5 gn peak 1 sweep cycle 10-150 Hz	≤5%
Vibration Endurance in each of 3 axes	1.0 gn peak 20 sweep cycles 10-150 Hz	Non- energized

### Shock and Bump

Standard	IEC 60255-21-2 Class 1	
Test Identification	Test specification	Variation
Shock Response in each of 3 axes	5 gn, 11 ms, 3 pulses in each direction	≤5%
Shock Withstand in each of 3 axes	15 gn, 11 ms, 3 pulses in each direction	Non- energized
Bump Test in each of 3 axes	10 gn, 16 ms, 1,000 bumps in each direction	Non- energized

### Seismic

Standard	IEC 60255-21-3 Class 2	
Test Identification	Test specification	Variation
Seismic Response Horizontal, on each axis	7.5 mm/2.0 gn, 1 sweep cycle 1-35Hz	≤5%
Seismic Response Vertical	3.5 mm/1.0 gn, 1 sweep cycle 1-35Hz	≤5%

### Mechanical Characteristics

Mechanical life at load	Resistive 8 A/ 250 V DC	>10 <sup>5</sup> cycles
	L/R=40ms, 0.15 A/ 220 V DC	
Max operation frequency at rated load		600 cycles /hour

## ELECTRICAL ENVIRONMENT

### Clearances and Creepage Distances

Standard	IEC 60255-26, #10.6.3
Test Identification	Test specification
Pollution degree	2
Overvoltage category	III
Rated insulation voltage	300 V rms or d.c.
Clearances and Creepage Compliance	CAD drawings assessment

### Safety-related Electrical Tests

Standard	IEC 60255-27, #10.6.4
Test Identification	Test specification
Between Independent Circuits	5 kV 1.2/50 $\mu$ s 0.5 J 3 pulses of each polarity 2.0 kV ac rms for 1 minute
Any Terminal and Earth	5 kV 1.2/50 $\mu$ s 0.5 J 3 pulses of each polarity 2.0 kV ac rms for 1 minute
Across Normally Open Contacts	1 kV ac rms for 1 minute

### Electrical Environment and Flammability

Standard	IEC 60255-27, #10.6.5
Test Identification	Test specification
Single-fault condition	Assessment for Opened and Closed-circuit cases
Single-fault condition	Assessment
Maximum temperature of accessible parts at ambient temperature +40°C	< 80°C
Flammability of insulating materials, components and fire enclosures	Assessment

### Reverse Polarity and Slow Ramp Test

Standard	IEC 60255-27, #10.6.6
Test Identification	Test specification
Maximum voltage d.c.	V start-up + 20%
Minimum voltage d.c.	V shutdown - 20%
Ramp down/up gradient	1 V/min

## ELECTROMAGNETIC COMPATIBILITY (EMC)

### IMMUNITY

#### Electrostatic Discharge (ESD)

Standard	IEC 60255-26, #7.2.3, Acceptance criterion B	
Port	Enclosure	
Test Identification	Test specification	Variation
Air Discharge	8 kV	≤5%

#### Radiated Electromagnetic Field

Standard	IEC 60255-26, #7.2.4, Acceptance criterion A	
Port	Enclosure	
Test Identification	Test specification	Variation
Frequency sweep	10 V rms, 80 to 1000 MHz 1,400 to 2,700 MHz	≤5%
Spot frequencies	10 V rms, 80, 160, 380, 450, 900, 1,850 and 2,150 MHz	≤5%

#### Fast Transients (EFT)

Standard	IEC 60255-26, #7.2.5, Acceptance criterion B	
Port	Input and Output ports	
Test level	Test specification	Variation
Zone A	4 kV peak, 5/50 ns, 5 kHz	≤5%

#### Slow Damped Oscillatory Wave (HFD)

Standard	IEC 60255-26, #7.2.6, Acceptance criterion B	
Port	Auxiliary Power Supply, Input and Output	
Test Identification	Test specification	Variation
Common Mode	1 MHz 2.5 kV peak	≤5%
Differential Mode	1 MHz 1.0 kV peak	≤5%

#### Surge

Standard	IEC 60255-26, #7.2.7, Acceptance criterion B	
Port	Auxiliary Power Supply, Input and Output	
Test Identification	Test specification	Variation
Line-to-earth	4 kV peak	≤10%
Line-to-line	2 kV peak	≤10%

#### Conducted Disturbance Induced by RF Fields

Standard	IEC 60255-26, #7.2.8, Acceptance criterion A	
Port	Auxiliary Power Supply, Input and Output	
Test Identification	Test specification	Variation
Frequency sweep	10 V rms, 0.15 to 80 MHz	≤5%
Spot frequencies	10 V rms, 27 & 68 MHz	≤5%

#### Power Frequency Magnetic Field

Standard	IEC 60255-26, #7.2.10	
Port	Enclosure only	
Test Identification	Test specification	
Continuous ≥ 60 s	30 A/m - Acceptance criterion A	
Short time 1 s to 3 s	300 A/m - Acceptance criterion B	

## XRD-8 Supervision Circuit

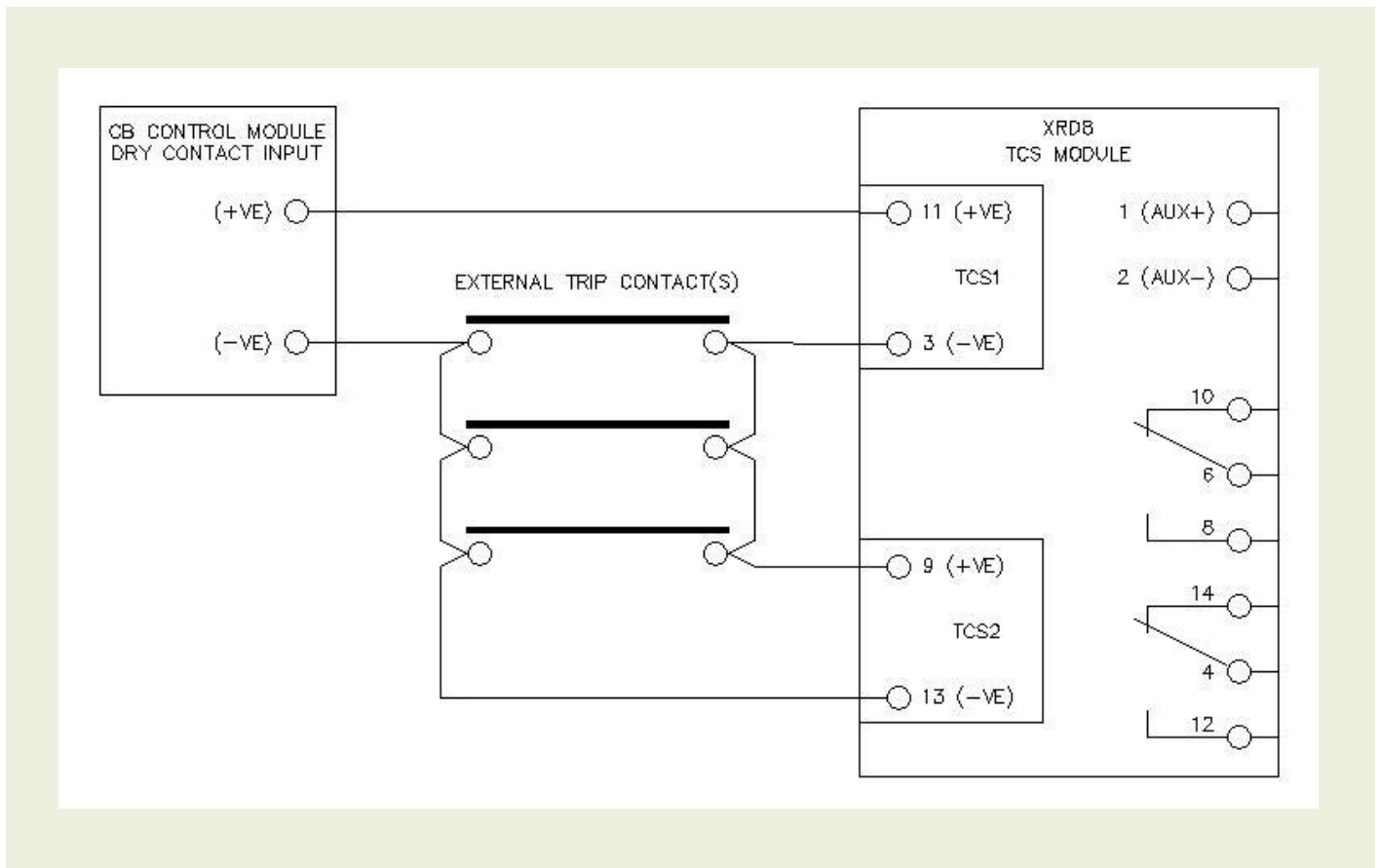

### Wiring Notes

Relays are shown in the non-powered (Alarm) condition.

Note the connection polarity for correct DC operation.

A wiring diagram is also printed on the front panel of the relay module for easy reference in the field.



## 19 Inch Rack Mount Rear Connect

## (TBD-R Terminal Block)



19 inch rack mount  
2U x 2U



Adapter plate for 2x units  
in a 2U x 4U rack frame



Adapter plate for 4x units  
in a 4U x 4U rack frame

## Surface Mount Rear Connect

## (TBD-R Terminal Block)



Panel cut-out to mount surface rear  
connect base

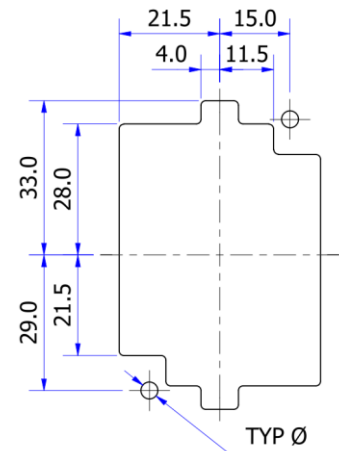
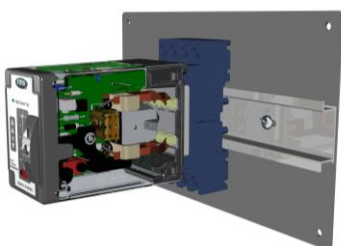

TABLE 1 - HOLE DIA	
PANEL THICKNESS (T)	HOLE DIA (Ø)
1mm < T < 2mm	3.6mm
T > 2mm	3.7mm

## Surface or Rail Mount Front Connect

## (TBD-F Terminal Block)



65

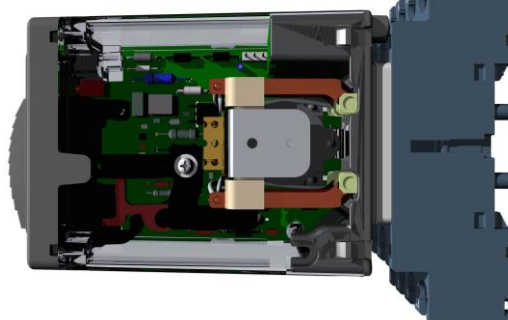

94

30



87

45

## Flush Panel Mount Rear Connect (TBD-R Terminal Block)

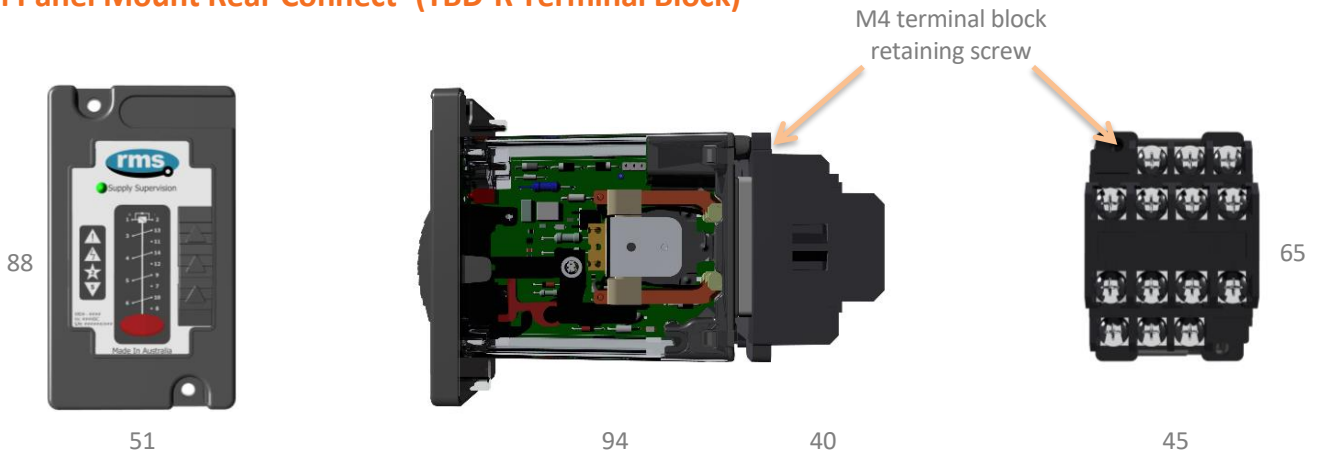

Outer dimensions in mm (Approx.)

Plug-in rear terminal block TBD-R1



Flush panel mounting  
Rear connect terminal block

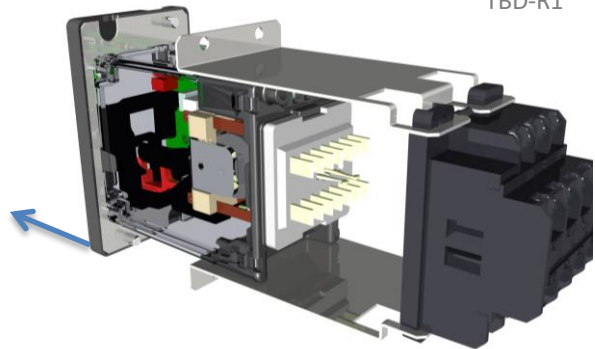

Rear connect terminal base secured to the front panel with optional retention plates - TBD-R2. Relay shown partially drawn-out of the panel.

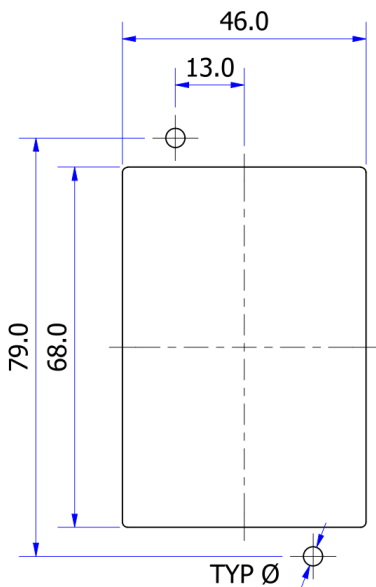

TABLE 1 - HOLE DIA	
PANEL THICKNESS (T)	HOLE DIA (Ø)
1mm < T < 2mm	3.6mm
T > 2mm	3.7mm

Panel cut-out to flush mount relay for use with rear connect TBD-R1 base

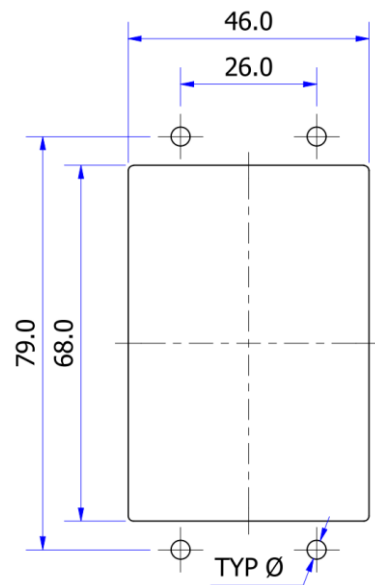

TABLE 1 - HOLE DIA	
PANEL THICKNESS (T)	HOLE DIA (Ø)
1mm < T < 2mm	3.6mm
T > 2mm	3.7mm

Panel cut-out to flush mount relay for use with rear connect TBD-R2 base

## Delta XRD-8 Order Codes

XRD -		8			Magnetic Actuator Trip Circuit Supervision Relay
Characteristic		A			Tavrida CM_16 Control Module
Nominal Operate Voltage		A			24 V dc
		B			32 V dc
		C			48 V dc
		D			110 V dc
		E			125 V dc
		F			220 V dc
		G			240 V dc
		H			250 V dc
Mounting Configuration		A			Surface or rail mounting without terminal block
		A-F			Surface or rail mounting including TBD-F terminal block
		A-R1			Surface mount including TBD-R1 terminal block
		B			Panel mounting without terminal block
		B-R1			Panel mounting including TBD-R1 terminal block
		B-R2			Panel mounting including TBD-R2 terminal block
				#	Refer note 1

NOTE 1 The Delta relay will be supplied for mounting as per the order code selection above. However, the relay mounting can be changed by the customer from DIN rail mount (Code A) to Panel Mount (Code B) or vice versa using the TBD-AC Relay Mount Conversion Kit. This provides more flexibility for the customer to manage changes at site without returning to the factory for modification. The front panel relay ID employs a # code in place of the mounting configuration code to indicate that either mounting configuration is possible. For example, XRD-8AD#  
The mounting configuration code **A** or **B** is shown on the escutcheon moulding.

## Delta Terminal Block Order Codes

TBD -		
Terminal Block Connection	F	Front connect
	R1	Rear connect
	R2	Rear connect using terminal block retention plates

## Delta Accessories

Relay mount components	TBD-AC	Relay mount conversion kit (Excludes terminal block)
Panel mount frames	TBD-AD	Dual - 4U x 2U frame to rack mount 2 high x 1 wide Delta relays
	TBD-AQ	Quad - 4U x 4U frame to rack mount 2 high x 2 wide Delta relays



**RMS Mors Smitt**  
A Wabtec company

[www.rmspl.com.au](http://www.rmspl.com.au)



Relay Monitoring Systems Pty Ltd design, manufacture and market a wide range of electrical protection and control products for application on high voltage power systems. The company's depth of manufacturing and engineering expertise is backed up by many years of experience since the formation of its predecessor, Relays Pty Ltd (RPL), in 1955. This experience combined with a broad base of field proven product types enables RMS to service specific customer needs by producing relays on demand and with typically short lead times.

Relay Monitoring Systems Pty Ltd

6 Anzed Court  
Mulgrave, Victoria 3170  
AUSTRALIA  
Ph: +61 3 8544 1200  
Fax +61 3 8544 1201  
Sales: [sales.rms@wabtec.com](mailto:sales.rms@wabtec.com)  
[www.rmspl.com.au](http://www.rmspl.com.au)  
[www.relays.com.au](http://www.relays.com.au)

#### **ISO9001 Quality Accreditation**

RMS holds BSI (British Standards Institution) registration number FS 604860 for the certification of a quality system to AS/NZS ISO9001:2008.

Due to RMS continuous product improvement policy the information contained in this document is subject to change without prior notice.

© 2019 Relay Monitoring Systems Pty Ltd

ABN 76 052 484 483