

## Features

- Ten year factory warranty
- Control Tone Insensitivity - Ripple signal control tones will not cause nuisance tripping.
- Frequency Insensitive System frequency shifts of a few Hz from nominal have minimal effect on trip voltage.
- Plug in measuring module
- Double insulated high impact polystyrol case
- Termination socket included for surface mounting enabling front or rear connection with optional DIN rail mounting
- Proven circuit designs based on over 20 years of field service in hundreds of varied & demanding applications
- Tolerance to shock & vibration for generator, compressor & mobile applications

## Operation

All power to operate the relay is derived from the sensed 3 phase supply therefore an auxiliary supply is not required. A normal and healthy 3 phase supply is indicated by a red LED on the front panel. The output relay will automatically reset when the 3 phase supply returns to a healthy condition.



2P740 depicted in a ZA12 case

## Description

Made in Australia

The 2P740 Series relays are solid state voltage sensing relays with electromechanical output contacts. Designed for application on 3 phase AC voltage systems the 2P740 is ideally suited to monitor power supply phase angle imbalance, undervoltage and reverse phase sequence. The 2P740 measuring circuitry keeps the output relay energised while the 3 phase supply remains within the specified imbalance window thus providing failsafe system protection.

In the event of any of the follow supply conditions the output relay contact will drop out:

- ◆ PHASE ANGLE IMBALANCE
- ◆ LOSS OF PHASE
- ◆ SUPPLY UNDER VOLTAGE
- ◆ REVERSE PHASE SEQUENCE

The 700 Series range of electronic measuring relays are manufactured as a modular approach to electrical system protection & control. Designed to meet rigid Australian & international specifications the 700 Series provide a flexible, cost effective & extremely reliable solution for a multitude of applications under electrically hostile conditions.

### PRINCIPLE OF OPERATION

The unit consists of a simple RC circuit across the R-Y phase such that point x will only be at the same potential as point p for a balanced supply of correct phase sequence. The solid state relay circuit is designed to release the relay at either a set out of balance voltage (X-P voltage), or a set undervoltage of the B-Y phase (relay supply). Special filtering circuitry is used to prevent high frequency or ripple control signals from affecting the operation of the relay.

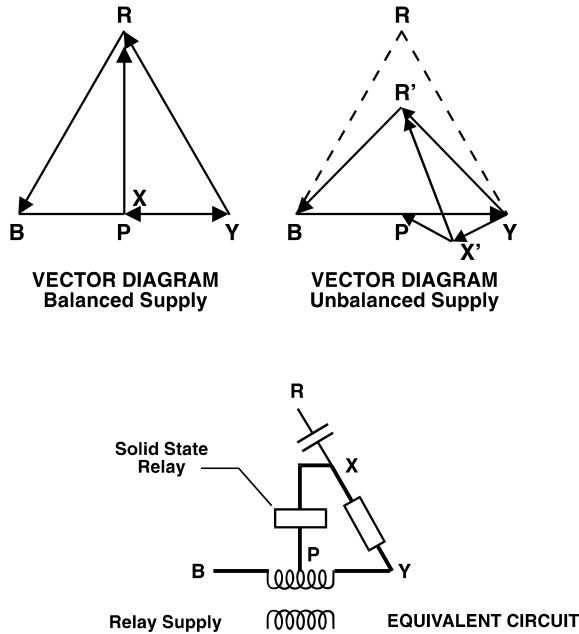

### NEGATIVE PHASE SEQUENCE

The relay will drop out when the negative phase sequence value corresponding to the relay setting shown below for the 110V AC is reached.

Setting (%)	Ph-Ph (V)	Ph-N (V)	Negative Phase Sequence
5	104.5	57.10	3.48%
6	103.4	55.80	4.21%
7	102.3	54.50	4.96%
8	101.2	53.19	5.72%
9	100.1	51.88	6.50%
10	99.0	50.56	7.29%
11	97.9	49.23	8.10%
12	96.8	47.90	8.92%
13	95.7	46.56	9.76%
14	94.6	45.21	10.62%
15	93.5	43.86	11.50%

Negative phase sequence chart – 110V AC

### PHASE REVERSAL PROTECTION

The 2P740 relay can be used for transportable cranes, refrigerated transporters, etc., which on being connected from one supply to another require phase reversal protection. The advantage of the 2P740 for this application is the added protection of phase failure and undervoltage.

### VOLTAGE SELECTION SCHEMES

The 2P740 relay can be applied in automatic voltage selection schemes to change over from a primary 3 phase supply to a secondary 3 phase supply if any phase of the primary supplies has faulted. A number of 2P740 relays may be cascaded to allow selection between 2, 3 or 4 independent 3 phase supplies.

For this application an external 4 C/O relay with heavy duty contacts is required to be driven from one of the 2P740 outputs. The 2P740 2.5s time delay setting is recommended for this application.

A single phase representation for automatic selection between multiple 3 phase supplies is depicted below:

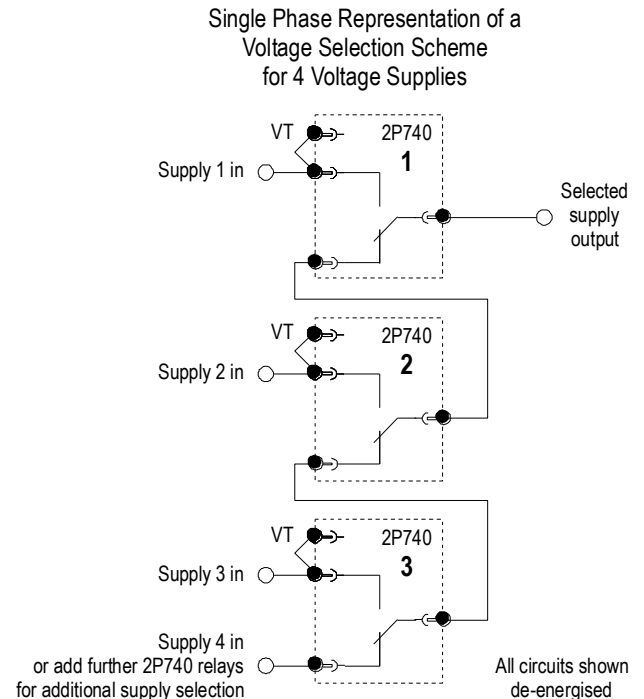

### MOTOR PROTECTION

The 2P740 phase failure relay has the sensitivity to detect the voltage unbalance caused by a motor single phasing. In most instances even a motor with no load and no other loads connected to the open phase will be detected when single phasing. The 2P740 relay is ideal for detecting phase failure and unbalance of HT lines and for this purpose 110V relays are also available. As the 2P740 detects the presence of negative sequence voltage a relay connected on the load side of a three phase transformer will detect a blown fuse or high impedance in one phase of the supply to the transformer, regardless of the transformer winding connections.

Pump motors on the end of a HT line with fuse protection and therefore high probability of single line outages are an obvious application for the 2P740 relay.

### 3 PHASE UNDERVOLTAGE

It is a useful undervoltage relay in that phase angles are also monitored. As an example three single phase undervoltage relays may not detect an open phase which is connected to a healthy phase through a low impedance load. The 2P740 relay however will detect this condition due to the change in phase angles. In using the 2P740 relay as an undervoltage relay it must be remembered that only the B-Y voltage is monitored directly. The other two  $\emptyset$  to  $\emptyset$  voltages are monitored for correct phase angle and voltage balance with respect to the B-Y voltage. The difference in percentage undervoltage expressed as phase to phase and phase to neutral must also be appreciated. As a guide, when two  $\emptyset$  to  $\emptyset$  voltages are equally reduced as shown - the relationship is as follows:

- 95%  $\emptyset$  to  $\emptyset$  = 90%  $\emptyset$  to N
- 90%  $\emptyset$  to  $\emptyset$  = 80%  $\emptyset$  to N
- 85%  $\emptyset$  to  $\emptyset$  = 69%  $\emptyset$  to N

### TERMINAL BASE WIRING

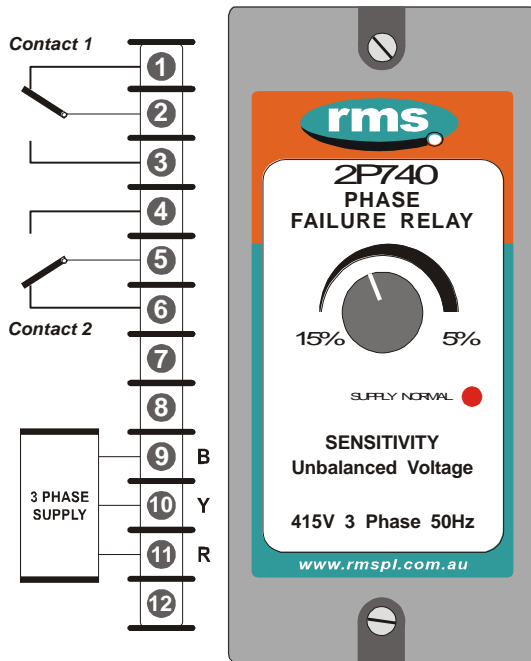

### INSTALLATION GUIDELINES

#### A SET TIME DELAY JUMPER

- Loosen two (2) front panel screws & un-plug the module from the terminal block;
- Locate Time Delay jumper & position for desired time delay setting

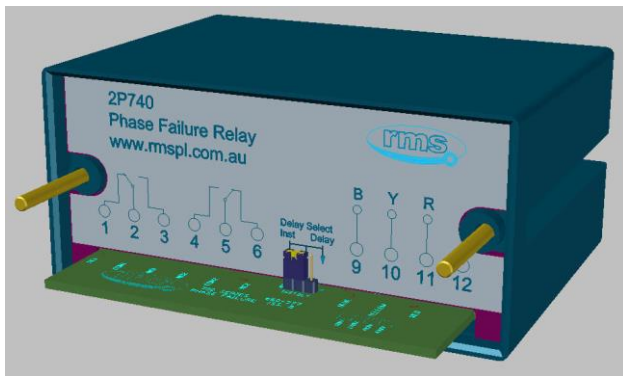

#### B PHASE SEQUENCE WIRING

- Wire **BLUE** (B) wire (Phase) to terminal 9
- Wire **YELLOW** (Y) wire (Phase) to terminal 10
- Wire **RED** (R) wire (Phase) to terminal 11

#### C REDUCE IMBALANCE SETTING

- Replace module after terminal block mounted & wiring has been checked to local regulations;
- Set imbalance to 15% & check operation;
- If LED fails to illuminate, transpose the **RED** wire to terminal 10 & the **YELLOW** wire to terminal 11;
- Check operation while reducing the phase imbalance setting to the lowest possible level which does not result in nuisance tripping.

## Technical Data

### SENSING SUPPLY

3 phase 3 wire connections

Standard 50Hz versions:

2P740-A	110VAC	50Hz
2P740-C	240VAC	50Hz
2P740-E	415VAC	50 Hz
2P740-F	440VAC	50Hz
2P740-G	230VAC	50Hz
2P740-H	400VAC	50Hz
2P740-J	380V AC	60Hz

Supply range:

Ph-Ph -15% to +10% all models

### INTERNAL POWER SUPPLY CAPACITY

Driven from B-Y: 31.25V DC +/- 1.25V DC

### BURDENS

Version	YB	YR	BR
110V	< 3.9 VA	< 0.2 VA	< 0.2 VA
415V	< 3.4 VA	< 0.5 VA	< 0.4 VA
440V	< 3.9 VA	< 0.6 VA	< 0.5 VA

### OUT OF BALANCE SETTING

Adjustable 5 to 15% expressed as phase to phase voltage difference as a % of nominal voltage when two phase to phase voltages are reduced equally with a third at nominal. The equivalent negative sequence voltage expressed as a % of nominal phase to neutral voltage would be 10 to 31%.

### UNDER VOLTAGE DETECTION

80% fixed expressed as a phase to phase voltage % of nominal.

### UNDERVOLTAGE HYSTERISIS

10% of undervoltage setting  
i.e. 70% drop out & 77% pickup

### SINGLE PHASE SENSITIVITY

5% to 15% of Nominal input - Front panel settable  
Pickup Hysteresis 33% of Sensitivity setting (i.e. 15% drop out, 10% pickup)

### OPERATING DELAY

Drop out: User selectable: Instantaneous or 2.5 sec +/-10%  
Pickup: 340+/-10ms from restoration of nominal conditions.

### OUTPUT CONTACTS

2 C/O with 1KV isolation across contacts  
Picked up in nominal state. Contacts drop out on Under-voltage or any phase error above setting.

### SWITCHING CAPACITY

10 Amp 240V AC resistive  
10 Amp 24V DC resistive

### FRONT PANEL LED INDICATION

A normal and healthy 3 phase supply is indicated by a red LED on the front panel. This LED will be extinguished to indicate an abnormal condition.

### OPERATING TEMPERATURE RANGE

-5 to 55 degrees C.

### INSULATION WITHSTAND

In accordance with IEC 255-5: 2KV RMS between input & frame, output & frame, & output & input. 1.2/50 5KV impulse between each terminal & earth, between circuits not normally connected together & between terminals of the same circuit.

### NOISE IMMUNITY

Withstands the high frequency interference test detailed in IEC 255-22-1.

# Mounting Details

Note: \* Where DIN rail mounting is required specify DIN Rail Mounting Kit P/N 290407157

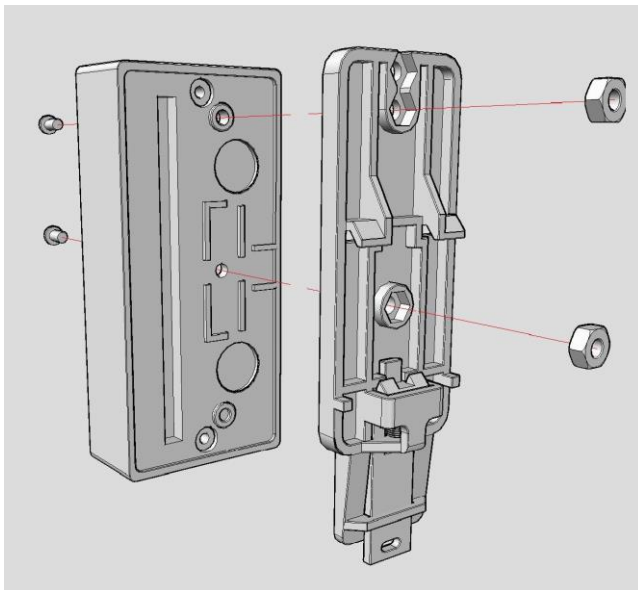
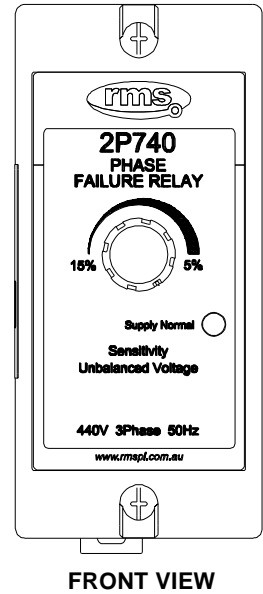
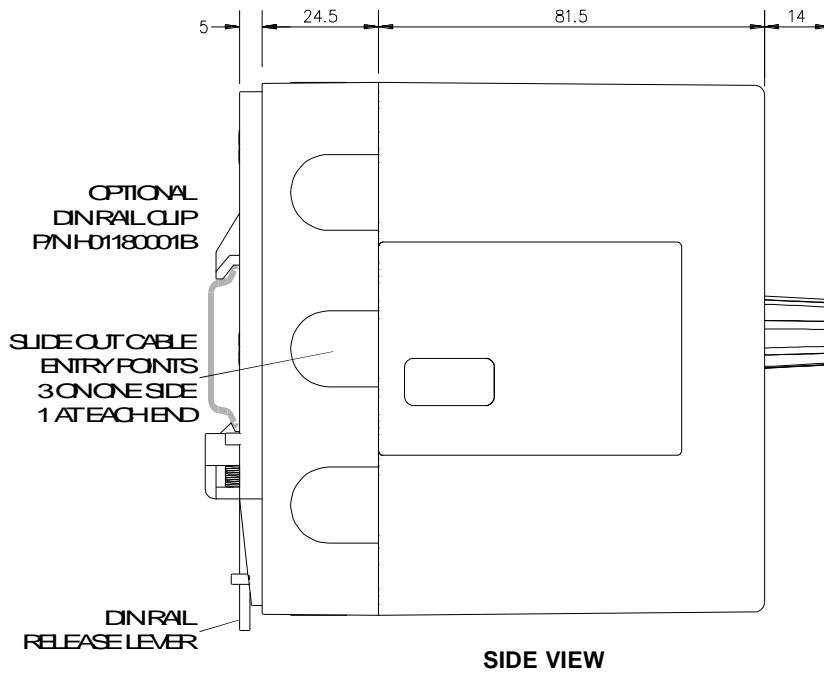

**DIN RAIL MOUNTING KIT**

Kit number 290-407-157  
Note orientation of terminal block.  
Drill 2 x 4.2mm holes.  
Fit M4 x 8 screws & nuts.

PROTECTION & CONTROL  
**rms**

SD1-500040  
Iss A (2/11/03)

DIN rail clip fitting detail – Specify DIN Rail Mounting Kit P/N 290407157

## Ordering Information

Generate the required ordering code as follows: e.g. 2P740-AAA

General Type	Order Code		
	1	2	3
2P740	-		

### 1 SENSING SUPPLY

- A 110V 50Hz
- C 240V 50Hz
- E 415V 50Hz
- F 440V 50Hz
- G 230V 50Hz
- H 400V 50Hz
- J 380V 60Hz

### 2 DIN RAIL MOUNTING KIT (P/N 290-407-157)

- A Not required
- B Required

### 3 FACTORY DROP-OUT DELAY SETTING

- A Instantaneous (Default)
- B 2.5s

Note: The nominated Order Codes for positions 2 and 3 are not shown on the product as the configuration may be changed by the user after it leaves the factory.