

Features

SYSTEM FEATURES

- Large back lit display panel
- System status LED indicators
- Simple menu setting procedure
- Wide auxiliary supply range with fail alarm contact
- Self diagnosis and fail alarm
- Size 4M56-S draw out case
- Made in Australia

VOLTAGE CONTROL

- Line drop compensation with 1A and 5A CT inputs
- Z Compensation
- 63.5 and 110V AC VT inputs
- Definite time and inverse time delays
- Independent fine and coarse voltage bandwidth windows
- Over and under voltage alarms
- Under voltage blocking function
- Tap change fail alarm
- Two digital input load step stages
- Overcurrent blocking

METERING AND EVENT RECORDING

- Line voltage display
- Line current display
- Tap position indicator
- Tap rate of change alarm
- Tap change event counter
- Tap position mA output
- Line voltage mA output

COMMUNICATION

- USB front programming port
- Non platform specific PC programming software: μ MATRIXwin
- Optically isolated RS485 network communication port
- MODBUS RTU compatible network protocol

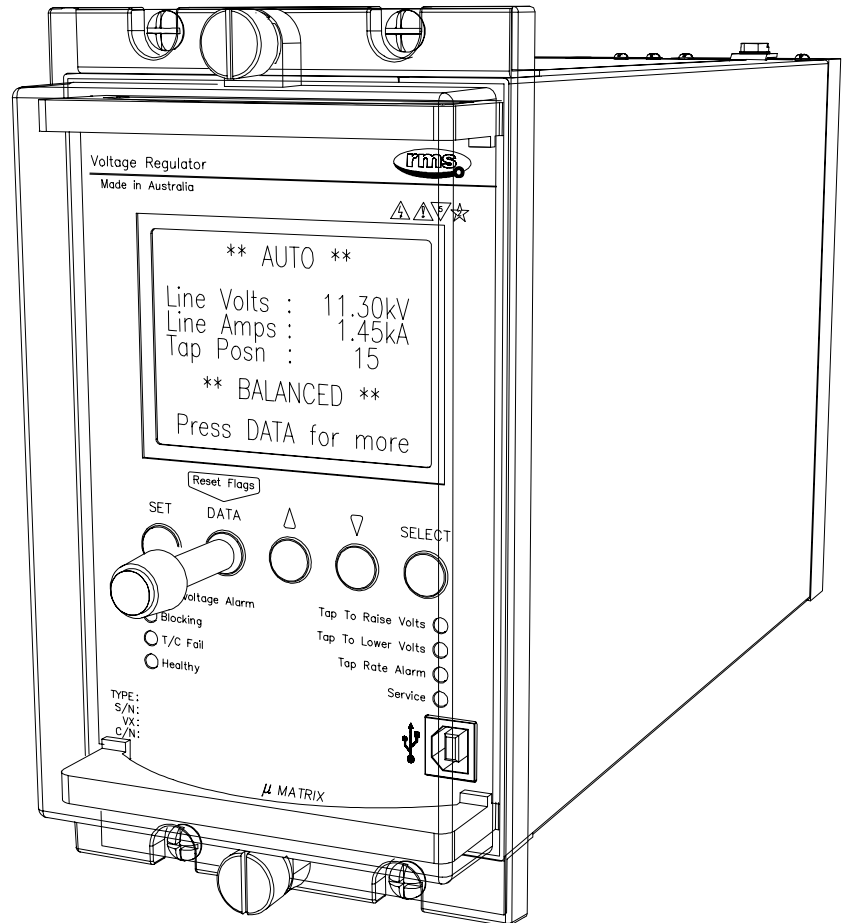

2V164-S depicted in a size 4M56-S draw out case

Application

Made in Australia

The 2V164 Series relays are designed for the control of motor driven on-load power transformer tap changers.

The 2V164 Voltage Regulator Relay continuously monitors the transformer output voltage and current and provides "RAISE" and "LOWER" control commands to the on-load tap changer such that the load centre is automatically maintained within acceptable limits. Small variations in supply frequency will not affect the system performance.

When designing the 2V164, considerable emphasis was placed on producing a relay, which would be very simple to install, set up and operate in the field. The result is a simple yet effective and very dependable voltage regulator relay available at a competitive price. The standard Micro MATRIX human machine interface (HMI) is combined with fully solid state voltage sensing and measuring circuitry to provide high accuracy, simple set up and flexible operation.

PARALLEL CONTROL SCHEMES

Parallel control schemes are available to meet a range of transformer control configurations based on the master / follower principal. These systems are supplied fully wired in 19" sub rack frames ready for integration into customer panels. Up to 4 transformers operating in parallel on one or two groups are possible.

For further details refer to the RMS 1M122A, 1M122D and 2V165 technical bulletins which provide details on our range of transformer parallel control systems.

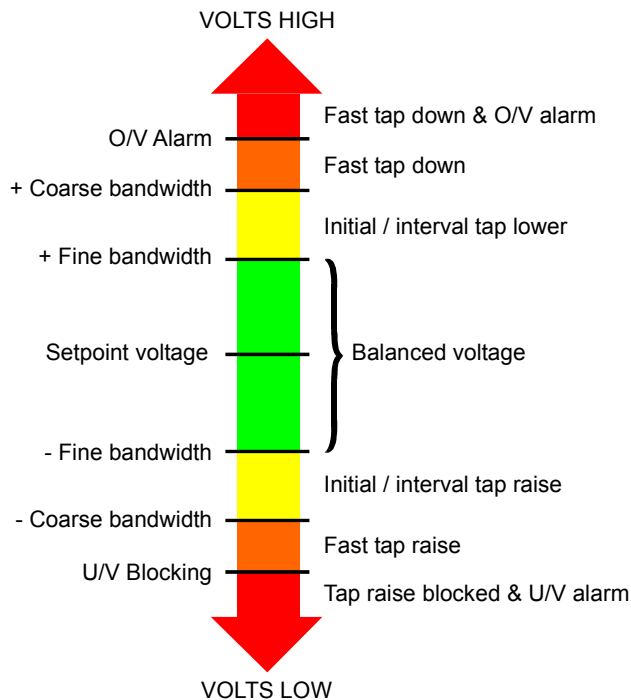

Figure 1: User defined voltage set points

SETPOINT VOLTAGE RANGE

90V to 130V in 0.1V steps.
110V and 63.5V nominal inputs.

“FINE” VOLTAGE BANDWIDTH SETTING (SENSITIVITY)

0.3 V to 5.0V in 0.1V steps.

The bandwidth setting should be made in accordance with the relative step voltage of the tap changer. A narrow bandwidth may result in the tap changer *hunting* between adjacent taps.

INITIAL RAISE / LOWER TIMER

10s to 300s in 10s steps.

The initial time delay between the detection of an error in the monitored voltage and the resultant tap change output, is switch selectable as either a definite time or true inverse time response.

The initial time delay starts when the voltage deviation exceeds the upper or lower limit. The respective instantaneous HIGH / LOWER LED illuminates.

If the deviation falls back to within bandwidth limits before the pre set time delay is completed, the timer is reset.

At the completion of the pre set time delay the respective RAISE / LOWER tap output contact will close.

INTERVAL TIME DELAY

1s to 100s in 1s steps.

The interval time delay only becomes active when the initial delay has caused a tap change but without affecting a balanced condition, ie. if more than one tap change operation is necessary to bring the voltage within set limits.

INVERSE TIME DELAY CHARACTERISTIC

In the inverse time mode, the initial time delay is inversely proportional to the ratio of deviation to bandwidth down to a minimum of a one-second delay. For example:

- ◆ When the detected error is equal to the selected bandwidth the time delay is equal to the delay setting.
- ◆ For a detected error of N times the selected bandwidth, the time delay is 1/N times the delay setting.

Voltage Control Functions

“COARSE” VOLTAGE BANDWIDTH SETTING

1V to 20V in 1V steps.

1s to 60s in 1s steps.

A second independent voltage control window can be set with a definite time delay. This can be used for a fast tap change function for large voltage deviations, which are outside the fine bandwidth window.

UNDER VOLTAGE BLOCKING FUNCTION

60V to 90V in 1V steps.

0s to 60s in 1s steps.

An undervoltage blocking function is combined with a definite time delay output.

Undervoltage blocking suppresses tap change operations during a system breakdown to avoid the tap changer mechanism from being driven to the top tap. The self reset Blocking alarm relay is activated when this element has timed out and a message reported on the HMI.

OVER VOLTAGE ALARM

110V to 140V in 1V steps.

0s to 60s in 1s steps.

An overvoltage alarm is combined with a definite time delay output. The self reset overvoltage alarm relay contact is activated when this element has timed out and a message reported on the HMI.

OVER CURRENT BLOCKING

50 to 150% in 5% steps – Can also be set to OFF

0s to 60s in 1s steps

Reset: >0.97Iset

When timed out all tap commands are inhibited / cancelled.

The self reset Blocking alarm relay is activated when this element has timed out and a message reported on the HMI.

LINE DROP COMPENSATION

Resistance and reactance compensation: 0V to 20V in 0.1V steps

Settings are provided to cater for *in phase* and *in quad* connections, with either positive or negative reactance compensation.

Correct setting of the LDC requires the calculation of the resistive and reactive line-drops as a voltage with reference to the secondary side of the VT and the setting of the instrument transformer for IN PHASE or IN QUAD connection. Z compensation is also available: 0 to +15% setting range.

The LDC function does not effect the under or over voltage alarm set points. These operate from the direct voltage measurements.

VOLTAGE LOAD STEP INPUTS

-10% to +10% of the set point voltage in 0.5% steps

Two independent load step stages are provided. The voltage reduction or boost level for each stage can be independently set while a separate digital input is provided to initiate each stage. If both stages are initiated then the stage 2 level is operative.

OPERATIONAL INDICATORS

Red LED's on the front panel indicate the following conditions:

- Over voltage Bus voltage above alarm setting
- Blocking BUS voltage / current outside block settings
- Tap change fail Tap change time out alarm
- Raise volts Flash when timing / On for Raise tap initiate
- Lower volts Flash when timing / On for Lower tap initiate
- Tap rate Tap rate alarm level exceeded

TAP CHANGE FAIL ALARM

10s to 300s in 10s steps.

The tap change fail alarm timer is initiated when an out of bandwidth voltage error is detected. Time out will result in the alarm contact closing. The alarm timer and contact is reset when the sensed voltage has moved back to a balanced condition.

AUTO / MANUAL MODE CONTROL INPUT

A digital input is provided to change the relay from AUTO to MANUAL mode.

In AUTO mode the 2V164 will monitor the voltage and current inputs and output tap raise / lower commands to maintain the load center in accordance with the relay settings.

In MANUAL mode tap raise and lower commands are inhibited.

The Blocking and Overvoltage alarm outputs remain active.

The relay fail alarm remains active.

Metering & Event Logging

TAP POSITION INDICATOR

A tap position indicator input is provided to enable the transformer tap to be displayed on the HMI. The output from the RMS type 2V200 Tap Position Transducer is required for this function to operate. Refer to the 2V200 Technical Bulletin for details.

TAP POSITION INDICATOR INPUT

For this function to operate an RMS type 2V200 transducer / sender unit is required at the tap changer. Refer to the 2V200 Technical Bulletin for application details.

The 2V200 is designed to interface to tap changes and convert one of the following parameters:

- an analogue voltage signal proportional to the tap position
- a binary coded decimal signal
- a BCD signal

The 2V200 converts any of these inputs to a frequency signal proportional to the tap position.

The 2V164 VRR is then simply programmed with the number of tap positions within the range 10 to 30. Scaling is carried out automatically so that the correct tap position is indicated on the 2V164 display.

A 4-20mA analogue output proportional to tap position is also provided by the 2V164 for local panel indication or interface to SCADA.

VOLTAGE DISPLAY

The HMI displays the line voltage. The VT ratio may be entered so that the HMI display reads in primary voltage. A 4-20mA analogue output is also provided.

Display range (Secondary): 10-145V
VT setting range: 0.11KV to 132.00KV

CURRENT DISPLAY

The HMI displays the line current from the LDC input. The CT ratio may be entered so that the HMI display reads in primary current.

Display range (Secondary): 0.1-1.35Is
CT setting range: 1A to 6.00KA

TAP CHANGE EVENT COUNTER

A record is maintained and displayed of the number of tap operations since this function was last reset. The tap rate indicator takes account of all tap changes initiated by the 2V164 tap raise / lower contacts. Manual taps initiated by external control contacts are not included.

RANGE OF TAP OPERATION

A record is maintained and displayed of the minimum and maximum tap position reached since this function was last reset.

TIME ELAPSED SINCE TAP COUNT RESET

A record is maintained and displayed of the time in hours since the tap count was last reset.

TAP RATE ALARM

The 2V164 records and displays the rate at which tap raise/lower commands have been output over the preceding 15-minute period. If the set point rate is exceeded (taps per hour), an alarm contact is picked up. This alarm contact is automatically reset when a tap rate lower than the alarm set point is updated to the display or when the tap count is manually reset. The tap rate indicator takes account of all tap changes initiated by the 2V164 tap raise / lower contacts. Manual taps initiated by external control contacts are not included.

TAP POSITION INDICATOR ANALOGUE OUTPUT

A single tap position indicator analogue output signal is provided for interface to an RTU. The analogue output is linked to the tap position as follows:

- Output: 4 to 20mA
Compliance voltage: 5V
Maximum burden: 250 Ohms
Accuracy: +/-3%
Analogue output:
- Tap 1 4mA
 - Tap N 20mA
- Where N = maximum selected tap setting

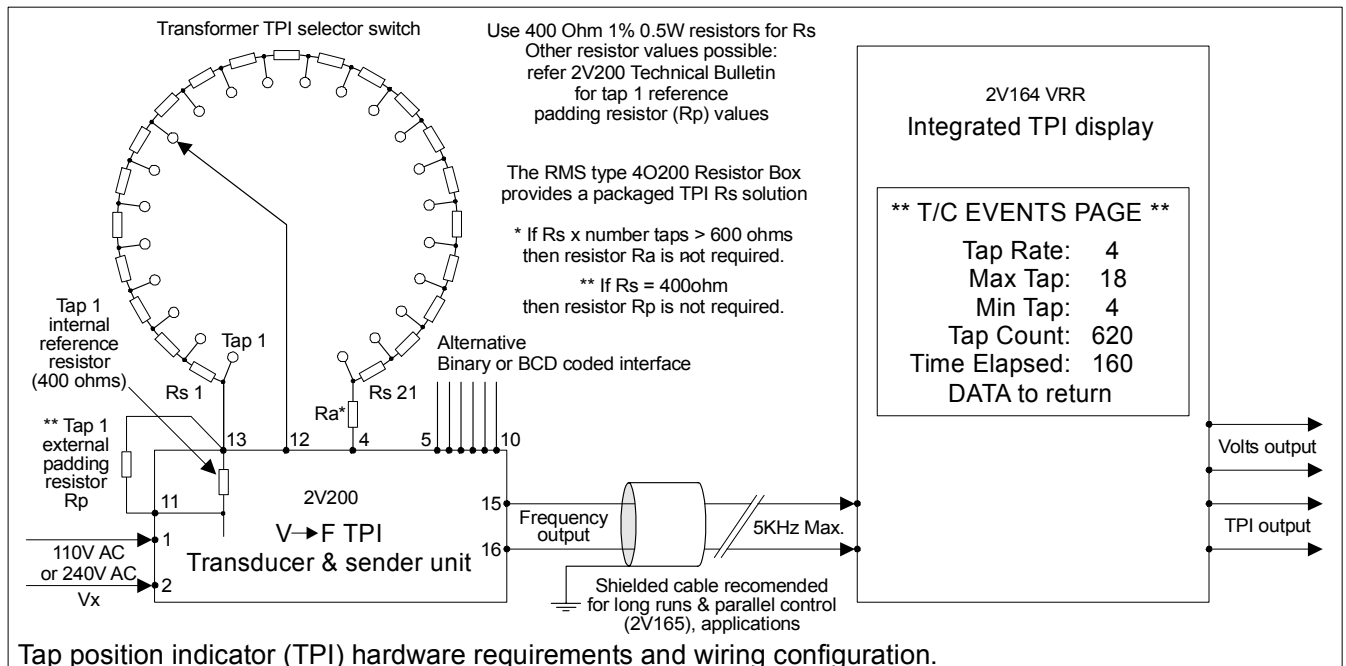

Figure 2

RELAY CONFIGURATION USING μ MATRIXwin

The purpose of the μ MATRIXwin application is to provide display, configuration and diagnostic facilities required to support the entire family of μ MATRIX digital relays. The prime functions of the application are:

Create a setting file off line

To create and view relay setting files at your PC without the need for a relay;

Relay setting

To download a setting file (UMP) into a relay connected to a PC;

To display and change settings in a connected relay;

Relay status

To display the Status of nominated inputs and outputs of a connected relay;

Relay Control

Manual raise / lower commands and resetting functions can be performed;

Commissioning

To export reports of setting parameters and status screen to confirm correct functionality during commissioning;

Upgrade relay software

To configure a μ MATRIX relay for a specific customer application;

To upgrade the operational software (UMX) of a μ MATRIX relay;

All current UMX software applications may be downloaded from:

www.rmspl.com.au/umatrix

Maintenance

To provide utility and diagnostic facilities at a technical level.

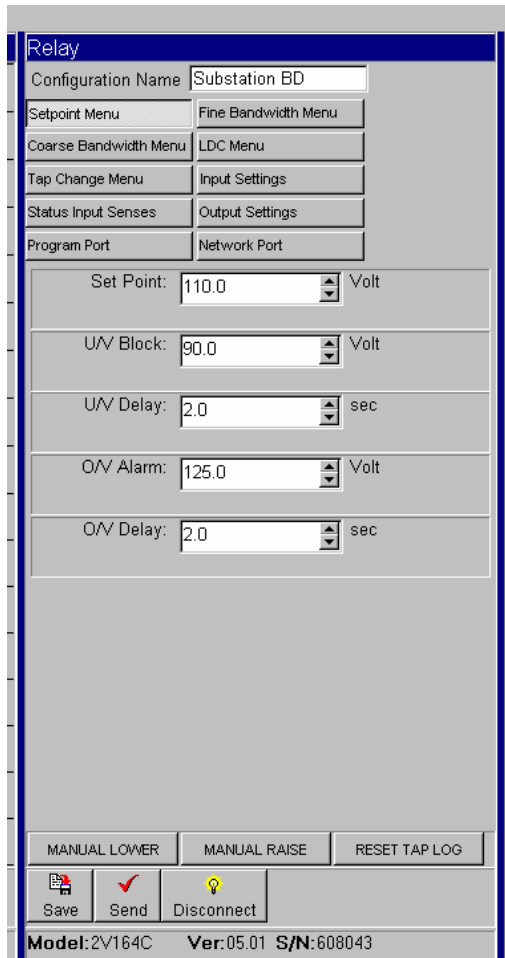

COMMUNICATION PORTS

Two (2) communications ports are available. The front USB programming port is provided as standard while the rear RS485 network port is available as an option.

Programming port

The programming port is accessible from the front panel of the relay via a USB physical link and PC configuration program supplied with the relay. The μ MATRIXwin configuration program is designed to operate with all relays from the μ MATRIX range and with all installed firmware version.

Network port

The network port is intended for applications where permanent connection to a master control system is required. An optically isolated RS485 physical layer is provided for this function.

The RS485 connection is intended for applications where multiple μ MATRIX relays are to be connected on a common communications bus.

Network Port Terminating Resistor

Where multiple relays are connected in a multi-drop configuration the RS485 comms. bus must have a 120 ohm terminating resistor fitted at each end. If the μ MATRIX-S relay is at one end of the transmission line a terminating resistor can be added by placing SW100-3 and SW100-4 in the ON position as depicted in the wiring diagram.

Network Port BIAS Resistors

Where a single relay is connected to the network, or where the relay is a long distance from other devices on the comms. bus, BIAS resistors may need to be fitted to ensure reliable operation. To simplify this configuration, BIAS resistors are fitted to each μ MATRIX-S relay and may be selected IN by setting switches SW100-1 and SW100-2 to the ON position as depicted in the wiring diagram. This bank of four switches can be accessed by withdrawing the relay module from its case, turning upside down and looking at the centre PCB near the rear terminal blocks.

PC TO μ MATRIX USB CONNECTION

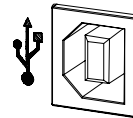

2V164-S front panel USB programming port

USB DRIVERS

The μ MATRIX-S USB port is configured as a Virtual Communications Port (VCP) and is operated through a PC COM port. USB drivers must be installed on the PC to enable correct communication. A ZIP file containing the driver files needed for this process may be downloaded from:

www.rmspl.com.au/umatrix

VOLTAGE SENSING CIRCUITRY

Nominal monitoring voltage

IN QUAD connection:	110V 50HZ
IN PHASE connection:	63.5V 50HZ
Sensing supply burden:	Less than 0.2VA
Thermal rating:	300V continuous

Nominal sensing frequency:	40 to 60Hz
----------------------------	------------

Voltage measurement secondary accuracy (110V tap):

Precision of voltage setting:	0.1V steps
Voltage pick up repeatability:	+/-0.1V from 90 to 120V
Voltage measurement resolution:	45mV
Resolution of voltage display:	0.1V
Accuracy of displayed voltage:	+/-0.1V from 90 to 120V

ACCURACY OF TIMERS

All timers +/-0.1s

LINE DROP COMPENSATION (LDC) INPUT

Nominal sensing current:	CT taps for 1A and 5A inputs
LDC input burden:	<0.5VA

Thermal rating:	3x nominal continuous
	3.5x nominal for 10 minutes
	6x nominal for 2 minutes
	100A for 1s on 1A input
	350A for 1s on 5A input
	700A for 1 cycle on 1A input
	2,500A for 1 cycle on 5A input

Note: M Series case terminals and CT shorting switches are limited to 400A for 1s.

LDC accuracy:	+/- 0.3V error at nominal 110V setting and 10 to 120% CT input
---------------	--

SET POINT HYSTERESIS

All voltage set points have a hysteresis equal to 50% of the bandwidth voltage setting. Other values available on application.

TAP CHANGE FEEDBACK FUNCTION

When a tap change command is output to the OLTC, the tap change fail timer is started. If a single tap change restores the sensed voltage to a balanced condition the relay is reset. If the sensed voltage remains in error the interval time delay will start based on one of the three methods described below: The required operating mode is selected using the UMX order code.

VOLTAGE MONITORING (Automatic mode) UMX2V164A

In this mode the 2V164 provides a 1s output pulse to initiate a tap change. This output pulse is then repeated at a rate set by the Interval Timer setting until the sensed voltage has moved back to a balanced condition. This is the simplest connection method as it does not require a hard-wired contact between the OLTC and the VRR.

The output pulse may be selected as continuous for application with linear voltage regulators. The continuous output contact and interval timer delay is reset once the sensed voltage moves back to the balanced condition.

OLTC AUXILIARY CONTACT METHOD UMX2V164B

In this mode an auxiliary contact on the OLTC is employed to signal completion of a tap change sequence. This signal is used by the 2V164 to pause the interval time delay until the previous tap change sequence has been completed.

The default 2V164 T/C feedback status input is set for a control voltage to be removed when the tap change starts (OLTC auxiliary contact opens) and re-applied when the tap change sequence is completed (OLTC auxiliary contact closes). The interval time delay is paused until the completion of the tap change sequence has been signaled.

The output pulse may be selected as continuous or to provide a 1s pulse output.

The continuous output contact and interval time delay is reset once the sensed voltage moves back to a balanced condition.

TPI FEEDBACK METHOD UMX2V164C

In this mode the 2V200 TPI transducer must be connected as per figure 2. The control sequence is as follows:

1. A voltage deviation starts the initial time delay.
2. The time delay expires and a tap change command is output.
3. The tap change contact will remain closed until a signal is received from the TPI transducer confirming that a tap change event has occurred.
4. The interval time delay is initiated.
5. Sequence 2 to 4 will repeat at the rate determined by the Interval timer setting until the sensed voltage has moved back to a balanced condition.

TAP POSITION TRANSDUCER FAIL (UMX2V164C only)

In the event that a 2V200 TPI transducer loses connection to the 2V164 or fails, any pending tap commands are blocked.

For TPI transducer (2V200) failure conditions, a 'TPI Fail' message is displayed on the MMI and the tap position displays as 'TPI Offline'. The TPI fail output contact is also set.

Normal tap change feedback and voltage regulation control function is automatically restored once the TPI transducer signal is recovered.

It should be noted that the 'TPI fail alarm' and the 'Tap change fail alarm' share a common output contact.

LINE VOLTAGE ANALOGUE OUTPUT

Output:	4 to 20mA
Compliance voltage:	5V
Maximum burden:	250 Ohms
Accuracy:	+/-3%
Analogue output:	Lower (4mA) set point range: 0V - 146V
	Upper (20mA) set point range: 50V - 146V

STATUS INPUT MINIMUM OPERATING CURRENT
10 mA P/U for 1 ms then reducing to 1.5 mA after 4 ms.

STATUS INPUT OPERATING TIME

Initiate input	Parameter	Delay
DC	P/U	<4 ms
	D/O	<16 ms
AC	P/U	<23 ms
	D/O	<33 ms

Technical Data

AUXILIARY SUPPLY

20-70V DC switchmode supply or
40-275V AC / 40-300V DC switchmode supply

Burden: Less than 10 watts with all output relays energized using 110V DC nominal supply.

Inputs:

A high efficiency switchmode power supply is incorporated which provides a low burden to the auxiliary supply.

Input Transients:

Withstands multiple high-energy transients and ring waves in accordance with IEEE28 - ANSI C26.1 Cat. II, accordingly:

- 0.5uS 100kHz 6kV O/C, 500A S/C, 4J
- 1.2/50uS 6kV O/C
- 8/20uS 3kA S/C, 80J clamped at 1,000V

Mains conducted EMI within limits specified by AS 3548 Class B.

Isolation:

The inputs are isolated from the outputs in accordance with AS3260 Class II Limited Current Circuitry, accordingly:

- Withstand voltage of 2.5kV RMS 50Hz for one minute
- Creepage and clearance distance greater than 4mm
- Output leakage current less than 0.25A to earth

Output Protection:

Outputs will withstand continuous short circuit. Output regulators and switching control regulator are thermally protected.

RELAY FAIL ALARM

A C/O alarm contact is maintained in the energized state when all of the following conditions are met:

- The auxiliary supply is applied
- The internal 24V DC rail is within acceptable limits
- The CPU hardware watchdog maintains a pulsing output

A CPU software watchdog records "suspect" events to an assert register and if necessary performs a soft restart.

A front panel green LED is illuminated when the relay is healthy. A separate flashing red LED indicates a software problem has been encountered which caused causing the CPU to perform a warm boot.

CASE

Size 4 draw out with 56 M4 screw terminals
Flush panel mount or 4U high 1/4 width 19 inch rack mount
IP51 rating

SHIPPING DETAILS

Each relay is supplied individually packed in pre formed cardboard cartons with internal moulded polystyrene former.

Weight: 3.5Kg
Size: 370(L) x 240(W) x 145(D)mm - Size 4 case

For large shipment individual cartons are packed in sturdy cardboard pallet boxes and surrounded by loose fill to absorb vibration and shock during transit.

ACCESSORIES SUPPLIED

- 1 x M4 self threading mounting screw kit P/N 290-406-151
- 2 x M4 terminal screw kit (28 per kit) P/N 290-407-153
- 1 x μMATRIX User Guide per order
- 1 x USB cable per order
- 1 x CD - μMATRIXwin software, setting files and applications per order

Technical Data

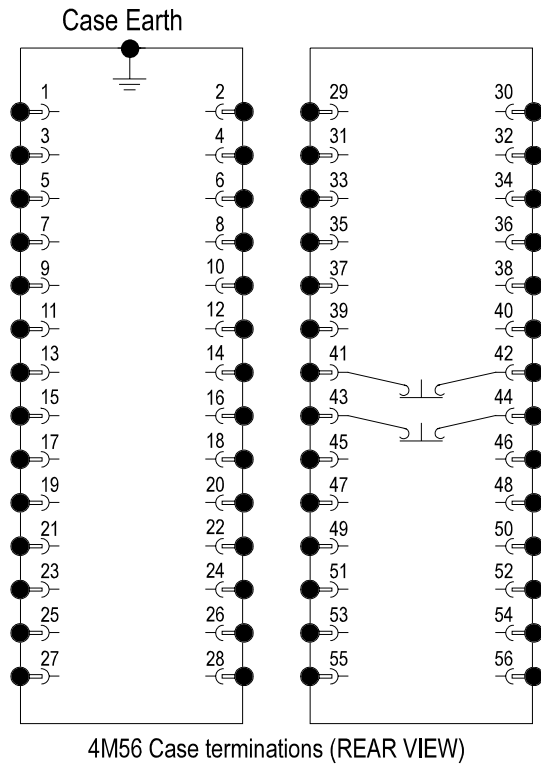

OUTPUT CONTACT RATINGS

IEC60255-0-2

Carry continuously	5A AC or DC	
Make and carry	0.5 s 20 A AC or DC	
L/R ≤ 40ms & V ≤ 300V	0.2 s 30 A AC or DC	
	AC resistive	1,250 VA
Break capacity	AC inductive	250 VA @ PF ≤ 0.4
I ≤ 5A and V ≤ 300V	DC resistive	75 W
	DC inductive	30 W @ L/R ≤ 40 ms
		50 W @ L/R ≤ 10 ms
Minimum number of operations		10 ⁶ at maximum load
Minimum recommended load		0.5W limit 10mA / 5 V

TRANSIENT OVERVOLTAGE

IEC60255-5 CLASS III

Between all terminals and earth	5 kV 1.2/50 us 0.5 J
Between independent circuits without damage or flashover	5 kV 1.2/50 us 0.5 J

INSULATION COORDINATION

IEC60255-5 CLASS III

Between all terminals and earth	2.0 kV rms for 1 min.
Between independent circuits	2.0 kV rms for 1 min.
Across normally open contacts	1.0 kV rms for 1 min.

AUXILIARY SUPPLY

IEC60255-11

Allowable breaks / dips in supply	≤ 20 ms
Collapse to zero from nominal voltage	

HIGH FREQUENCY DISTURBANCE

IEC60255-22-1 CLASS III

2.5 kV 1MHz common mode	≤ 3% variation
1.0 kV 1MHz differential mode	

ELECTROSTATIC DISCHARGE

IEC60255-22-2 CLASS III

6 kV contact discharge	≤ 5% variation
------------------------	----------------

FAST TRANSIENT

IEC60255-22-4

4 kV, 5/50 ns, 100 KHz repetitive	≤ 3% variation
-----------------------------------	----------------

TEMPERATURE RANGE

IEC68-2-1/2

Operating:	-5 to +55°C
Storage:	-25 to +75°C

HUMIDITY

IEC68-2-78

40°C and 95% RH non condensing	
--------------------------------	--

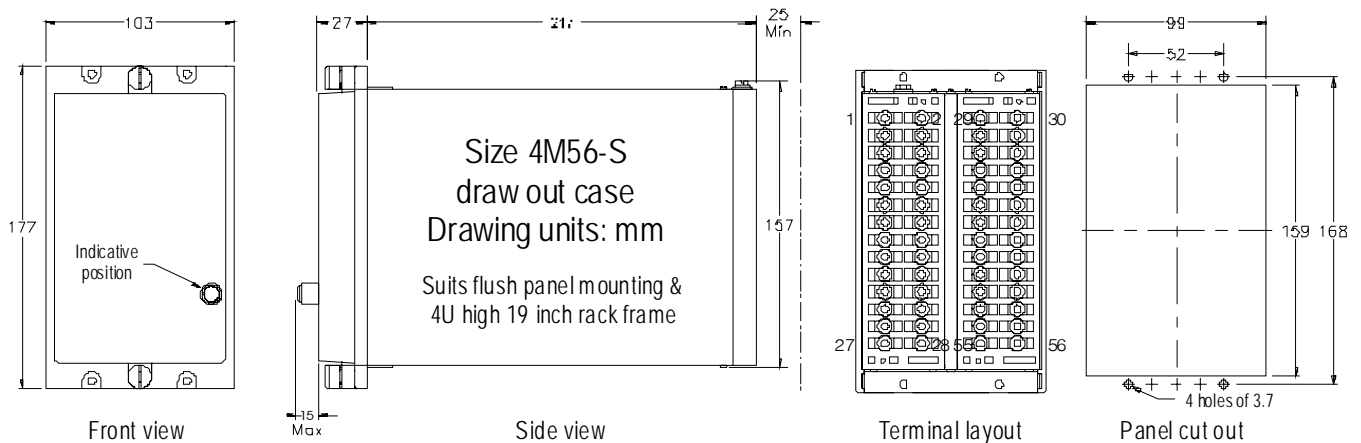

In QUAD Connection

Tap change feedback control mode depicted

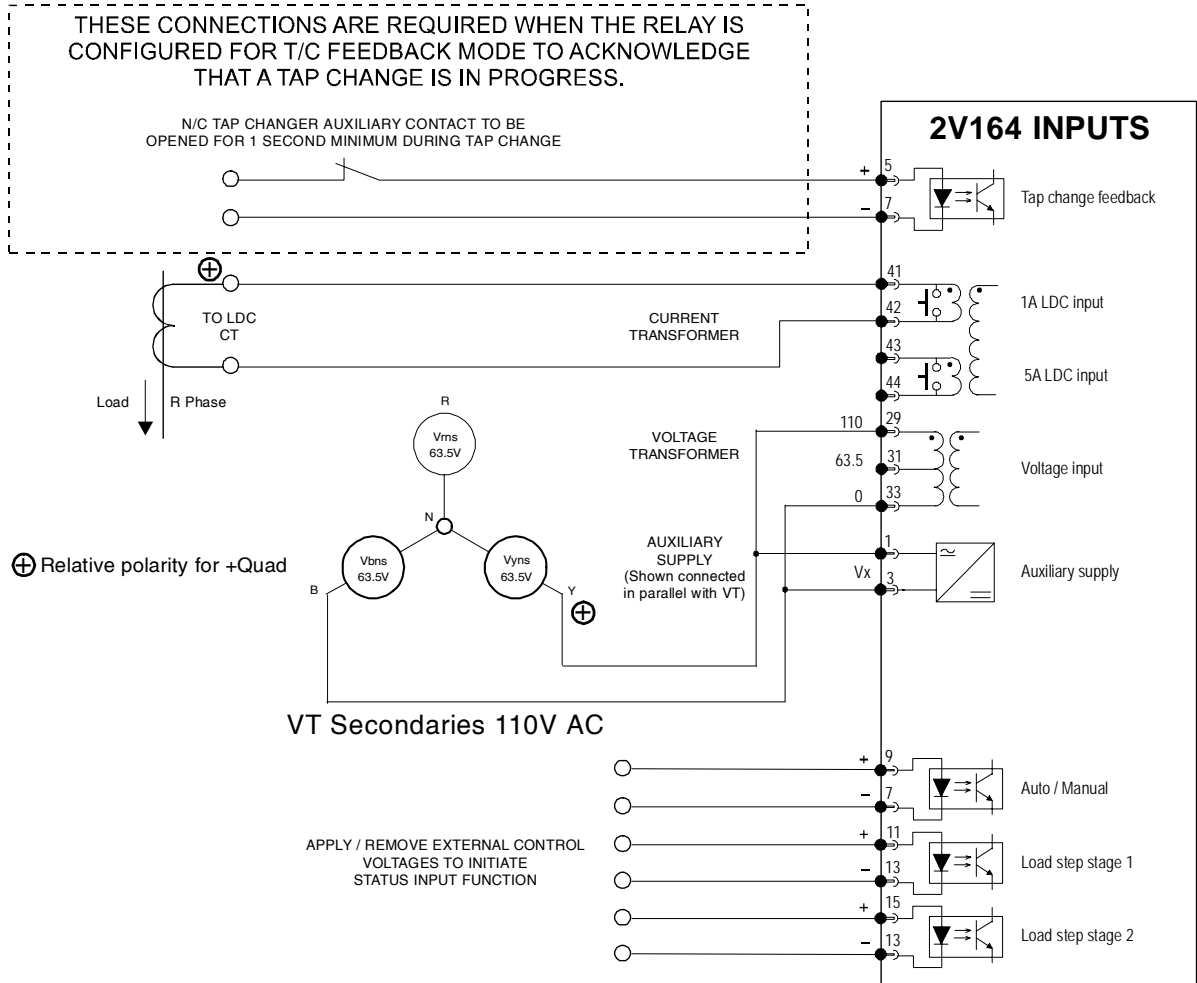

In PHASE Connection

Auto or TPI mode for tap change feedback control

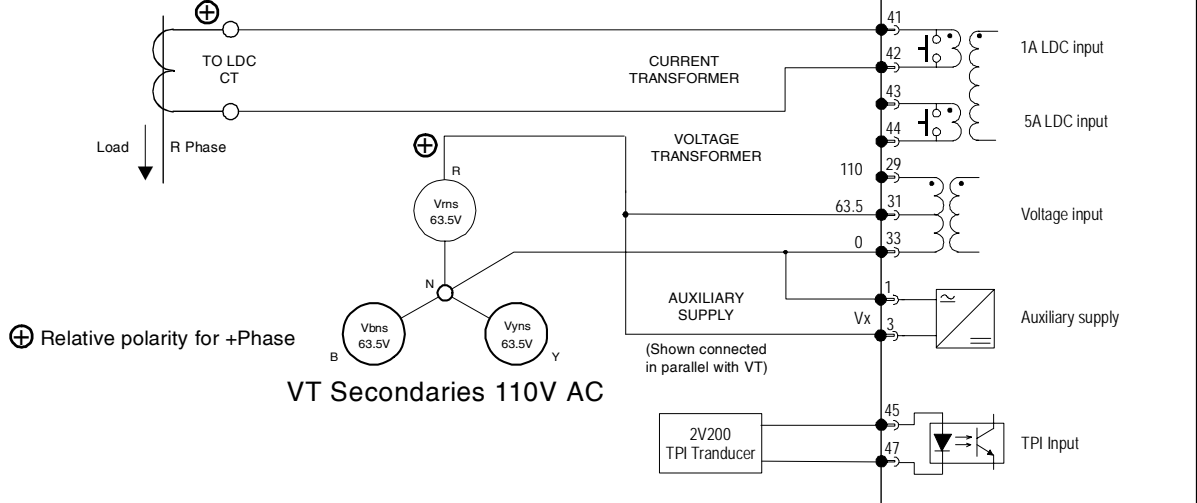

2V164 application diagram

All relay contacts are shown with a healthy supply applied, the 2V164 in a balanced condition, auxiliary supply connected in parallel with the 110V sensed voltage & 1 Amp CT tap LDC input wired.

Ordering Information

Generate the required ordering code as follows: e.g. 2V164-S-BDDAA

General Type	Order Code				
2V164-S	1	2	3	4	5

- 1 AUXILIARY SUPPLY RANGE**
 A 20-70V DC B 40-275V AC (300V DC)
- 2 DIGITAL INPUT OPERATING VOLTAGE – GROUP 1**
 A 24-80V AC/DC B 80-150V AC/DC
 C 150-275V AC (300V DC) D 18-275V AC (300V DC)
- 3 DIGITAL INPUT OPERATING VOLTAGE – GROUP 2**
 A 24-80V AC/DC B 80-150V AC/DC
 C 150-275V AC (300V DC) D 18-275V AC (300V DC)
- 4 ANALOGUE OUTPUTS**
 A Not required
 B Required 4 to 20mA
- 5 REAR COMMUNICATIONS PORT**
 A Not required
 B Required – Modbus protocol
- ! SELECT DEFAULT APPLICATION SOFTWARE**
 A UMX2V164A Voltage monitoring feedback – Auto mode
 B UMX2V164B OLTC auxiliary contact method
 C UMX2V164C TPI feedback method

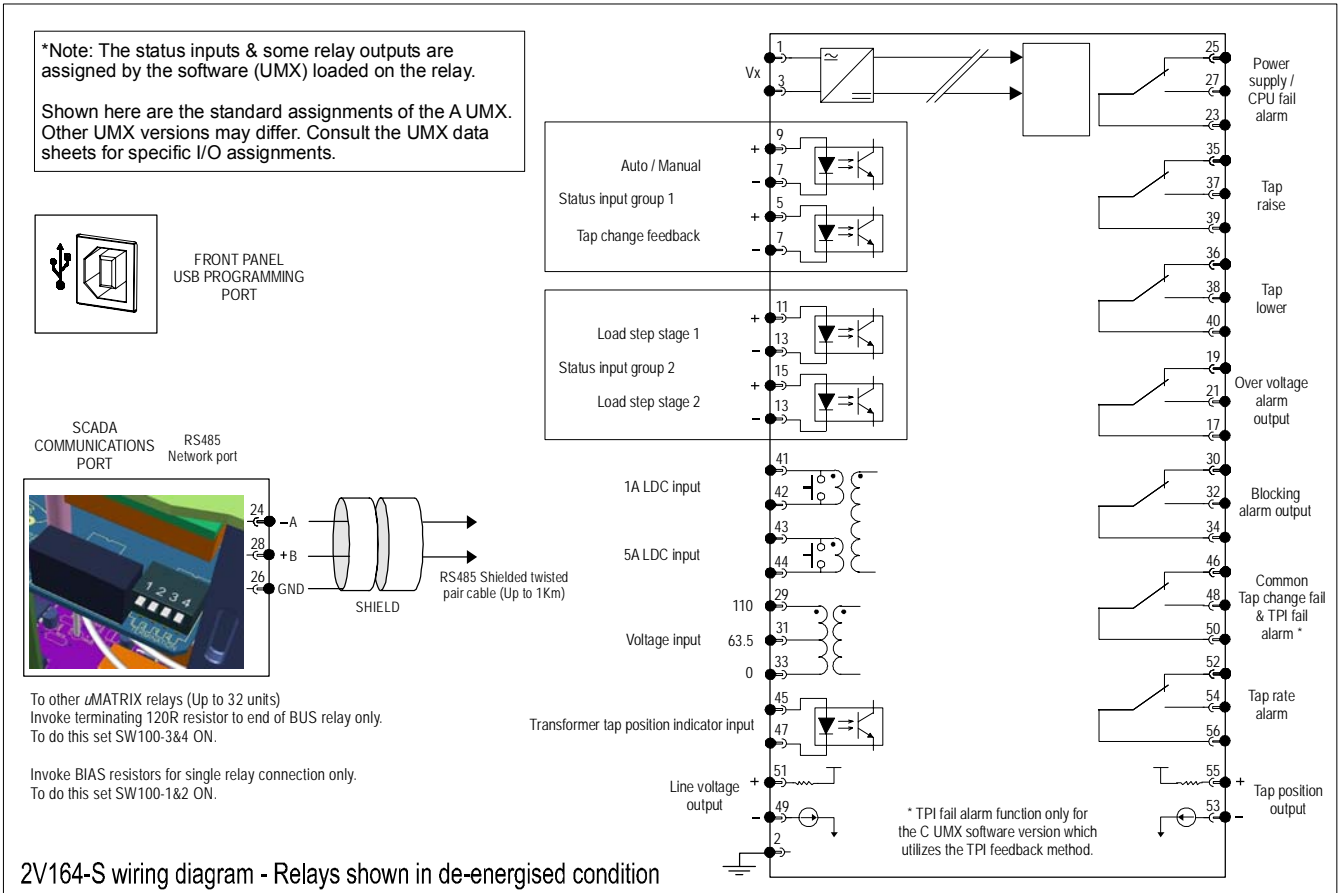

Australian Content

Unless otherwise stated the product(s) quoted are manufactured by RMS at our production facility in Melbourne Australia. Approximately 60% of our sales volume is derived from equipment manufactured in house with a local content close to 80%. Imported components such as semi-conductors are sourced from local suppliers & preference is given for reasonable stock holding to support our build requirements.

Quality Assurance

RMS holds NCSI (NATA Certification Services International), registration number 6869 for the certification of a quality assurance system to AS/NZS ISO9001-2008. Quality plans for all products involve 100% inspection and testing carried out before despatch. Further details on specific test plans, quality policy & procedures may be found in section A4 of the RMS product catalogue.

Product Packaging

Protection relays are supplied in secure individual packing cardboard boxes with moulded styrene inserts suitable for recycling. Each product & packing box is labeled with the product part number, customer name & order details.

Design References

The products & components produced by RMS are based on many years of field experience since Relays Pty Ltd was formed in 1955. A large population of equipment is in service throughout Australia, New Zealand, South Africa & South East Asia attesting to this fact. Specific product & customer reference sites may be provided on application.

Product Warranty

All utility grade protection & auxiliary relay products, unless otherwise stated, are warranted for a period of 24 months from shipment for materials & labour on a return to factory basis. Repair of products damaged through poor application or circumstances outside the product ratings will be carried out at the customer's expense.

Standard Conditions of Sale

Unless otherwise agreed RMS Standard Terms & Conditions (QF 907) shall apply to all sales. These are available on request or from our web site.



Relay Monitoring Systems Pty Ltd

6 Anzed Court, Mulgrave, Victoria 3170, AUSTRALIA

Tel: +61 3 8544 1200 Fax: +61 3 8544 1201 Email: rms@rmspl.com.au Web: www.rmspl.com.au