

## Features

- Colour coded 'finger safe' test sockets suit standard or shrouded type 4mm banana plugs
- 14 independent circuits suitable for CT or VT connections
- Test plug available with automatic CT shorting option
- Test plug fitted with insertion handles & locking screws
- Side label instructions on changing from normal service condition to the test condition
- Optional automatic DC auxiliary isolation function
- High current / voltage rating
- Compact & economic design
- Made in Australia

## Application

Test links are an important accessory for protection, metering & control panels. They enable test technicians to quickly & safely isolate protection relays so that test signals may be injected & system performance verified.

There are a number of advantages in performing injection tests at the protection relay panel:

- Reduction in down time of the equipment under test.
- Testing does not cause disturbance to wiring, terminals or equipment settings.
- Existing auxiliary supply to the equipment under test may be isolated.

The 4M300 Test Link Panel has been designed as a general-purpose isolation & test signal injection point. Standard 4mm diameter sockets are employed so that common banana plugs may be used to short CT inputs & connect test equipment.

Equipment under test need only be removed for servicing if problems are detected.



Figure 1:  
4M320-A Test Plug

## Description

Made in Australia

The **Test Block** type 4M300 comprises fourteen (14) test circuits, each of which is connected to a separate pair of terminals at the rear of the case. During the normal operation of the associated protection equipment, each pair of terminals are connected together by a circuit-shorting link. Changing the 4M300 Test Block from the normal service condition to the test condition is described below & depicted in figure 3:

### Test Circuit Access

Access to the circuits, for testing purposes, is gained by first removing the front cover. For the 4M300-B model the **Isolation Plug** is withdrawn & the circuit between terminals 13 & 14 interrupted. By routing the main DC supply to the protection scheme or relay through this circuit, removal of the Isolation Plug will thereby prevent inadvertent tripping of the protection during the ensuing tests.

### Test Plug Insertion

Insertion of the **Test Plug** type 4M320, isolates the live side circuits from the equipment side. The Test Plug carries 28 4mm 'finger safe' test sockets. These sockets are suitable for shrouded or standard 4mm banana plugs. Each test socket is identified by a number, which corresponds to the numbered terminal on the rear of the case when the Test Plug is inserted. The test socks are colour coded - BLACK to indentify the equipment side sockets & YELLOW to identify the live side sockets.

## RECOMMENDED WIRING LAYOUT

It is recommended that the Test Block is always wired with connections to the protective relay or scheme made to the EVEN numbered equipment side terminals. Connections to other equipment, e.g. CT's , VT's & DC supplies, should be made to the ODD numbered live side terminals on the Test Block. This ensures that when the Test Plug is used, the BLACK sockets of the Test Plug are the isolated relay circuits & the YELLOW sockets on the Test Plug are connected to the potentially live supplies as shown in figure 8.

Test equipment can be connected to the relay or scheme using the BLACK sockets in the Test Plug, & operation of contacts can be monitored. When using the 4M300-B Test Block, the DC supply may be used during testing by linking across sockets 13/14 & 15/16 of the Test Plug.

## CT SHORTING – MANUAL (External)

It is essential that the sockets of the 4M320 Multi-Finger Test Plug which correspond to the current transformer (CT), secondary windings are linked prior to the test plug being inserted into the test block. This ensures that the current transformer secondary windings are not open circuited when they are isolated from the protection relay scheme.

This may be achieved using external shorting links to ensure that the CT secondary windings are short circuited before they are disconnected from the protection relay or scheme, thereby avoiding dangerously high voltages.

The continuity of the shorting plug / wire links & their state of insulation should be checked prior to into the 4M300 test block.

## CT SHORTING – AUTOMATIC (Internal)

The 4M320 may be ordered with internal CT shorting links fitted to pre-designated positions as follows:

4M320-B Internal links between terminals 21-23-25-27  
Refer figure 8

Where these 4M320 test plug versions are employed it is essential that the CT circuits are wired to the 4M300 test block in the matching positions.

To Reiterate: The 4M320 requires the **USER** to ensure that the necessary shorting links - manual or automatic – are fitted prior to plugging into the 4M300 test block.

## TEST LEAD INSERTION

Before use the insulation of the flying leads should be visibly checked for damage.

Flexible banana test leads with shrouded plugs are recommended for operator safety. 2.5mm<sup>2</sup> multi-strand wire with PVC insulation is recommended for adequate current rating and flexibility.

## TEST PLUG INSERTION



To avoid high voltage shock hazard external CT circuits must **NOT** be open circuited. Shorting links must be in position **BEFORE** test plug insertion.

Insertion of the 4M320 connects the live side circuits to the YELLOW test sockets on the front panel. The equipment side circuits are connected to the BLACK test sockets on the front panel. Each test socket is identified by a number, which corresponds to the numbered terminal on the rear of the case when the Test Plug is inserted.

## FINGER SAFE TEST SOCKETS

**BLACK** - even numbered - equipment side sockets  
**YELLOW** - odd numbered - live side sockets



Figure 2: Close up view of the 'finger safe' test plug sockets that accept standard 4mm shrouded test plugs

Changing the 4M300 Test Block system from the normal service condition to the secondary injection test condition is achieved in three steps shown in figure 3 below:

**NORMAL SERVICE CONDITION**

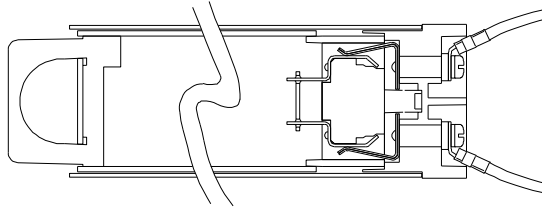

TOP VIEW

Shown with isolation plug fitted to short terminals 13 & 14 (4M300-B model only)

4M300-B Test Block Terminal Status

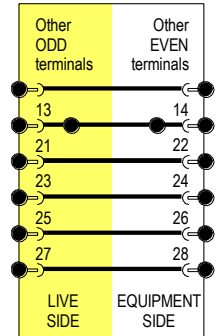

REAR VIEW

**Step 1 - DC AUXILIARY SUPPLY ISOLATION**

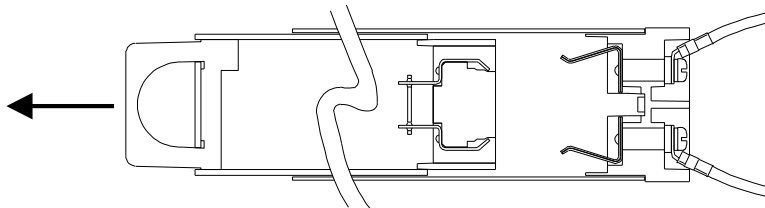

WITHDRAW DC AUXILIARY ISOLATION PLUG (4M300-B model only)  
DC auxiliary supply link between terminals 13 & 14 is removed

Auxiliary supply isolated - 4M300-B

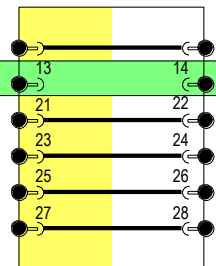

**Step 2 - AUTOMATIC CT SHORTING**

INSERT 4M320[B] TEST PLUG

Automatic shorting of CT's wired to terminals 22, 24, 26 & 28

Circuit isolating bar not yet engaged

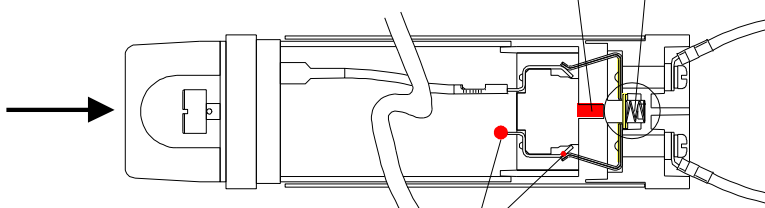

4M320 terminals touch  
Automatic CT shorting engaged

Equipment side & live side contacts shorted

CT shorting links engaged  
4M320-A Manual  
4M320-B Automatic

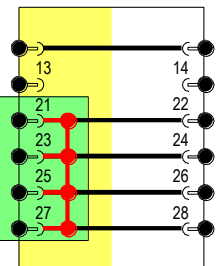

**Step 3 - CIRCUIT ISOLATION**

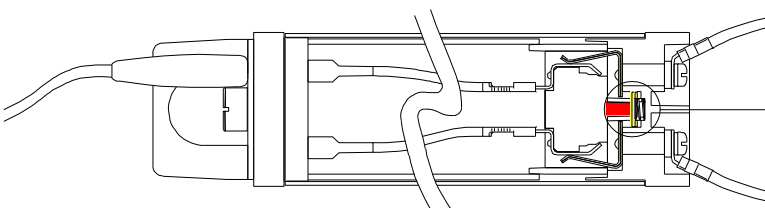

4M320[B] Test Plug fully inserted

Circuit isolating bar engaged  
Equipment side circuits isolated from live side circuits

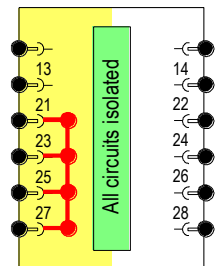

**SECONDARY INJECTION TEST CONDITION**

# Test Leads

## SHROUDED TEST LEADS

Two types of shrouded 'finger safe' test leads are available:

Part Number	Description	Quantity supplied per 4M320
310-230-075-1	Two ended test lead - 75mm	3
310-230-180-1	Two ended test lead - 180mm	3

Wire type: 2.5mm<sup>2</sup> multi-strand wire with yellow PVC insulation

## TEST LEAD PLUGS

Two types of shrouded plug are employed on each test lead as depicted in figure 4 & 5.

### Single Plug

The single plug is the most compact & may be plugged into any test socket.

### Dual Plug

The dual or 'piggy back' plug is larger & should be plugged into the test sockets on the outside edge of the 4M320. The lead emerging from the dual plug should face out from center of the 4M430 to ensure adequate clearance for other plugs.

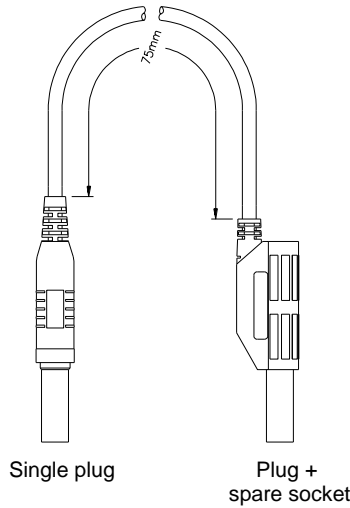

Figure 4: Two ended test lead - short

P/N 310-230-075-1 75mm wire length version depicted

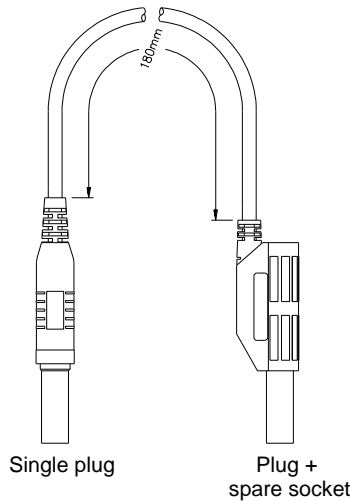

Figure 5: Two ended test lead - long

P/N 310-230-180-1 180mm wire length version depicted

## CONNECTING MULTIPLE TEST LEADS

Test leads may be linked in a daisy chain arrangement to perform manual CT shorting as described on page 2. Three (3) leads are required to short a group of four (4) CT circuits as follows:

1. Connect the first lead between sockets 21-23
2. Connect the second lead between sockets 25-27
3. Connect the third lead to link the dual plugs in sockets 21-25

An additional lead may be fitted into the third lead dual plug for a ground connection where required.



Figure 6  
4M300-B Test Link Plug  
Depicted in the normal service condition  
with the isolation plug installed

## Technical Data

**4M300-A TEST BLOCK** (Isolating Plug not fitted)  
14 Equipment side terminals (Even terminal numbers).  
14 Live side terminals (Odd terminal numbers).  
14 Live side to equipment side shorting links.

This arrangement provides for up to 14 independent circuits to be connected.

An isolating circuit is not provided on this model.

**4M300-B TEST BLOCK** (Includes Isolating Plug)  
14 Equipment side terminals (Even terminal numbers).  
14 Live side terminals (Odd terminal numbers).  
13 Live side to equipment side shorting links.  
1 Isolating circuit between terminals 13 & 14

This arrangement provides for up to 12 independent circuits to be connected.

An additional DC auxiliary circuit is provided with an isolating link across terminals 13 & 14. This circuit is automatically opened when the Isolation Plug is removed.

**4M320 TEST PLUG**  
28 test sockets suitable for 4mm banana plugs.  
Securing screws to retain the Test Plug during testing operations.

### CURRENT RATINGS

All CT circuits & terminals: 20A continuous  
(Terminal 1 to 28) 400A 1s

### VOLTAGE RATINGS

All circuits & terminals: 600V AC continuous  
320V DC continuous  
System auxiliary voltage: 40V DC minimum

### CASE TYPE

2M28 Size 2 28 terminals

### COMPLIANCE STANDARDS

IEC 60068-2-1, 60068-2-2, 60068-2-78  
IEC 60255-1, 60255-21-1, 60255-21-2, 60255-21-3, 60255-27  
IEC 60947-1, 60947-7-1

### INSULATION WITHSTAND

#### All Models

2KV AC RMS for 1 min: . between all terminals & all terminals & case.  
1.2/50 $\mu$ s 5KV impulse between any contact pair and either adjacent contact pair. All terminals and case.

#### 4M300-B Test Block & 4M320 Test Plug only

1KV AC RMS for 1 min. between terminals 13 & 14 when the isolation plug is removed.

### AMBIENT OPERATING TEMPERATURE RANGE

-10 to 55 degrees C.

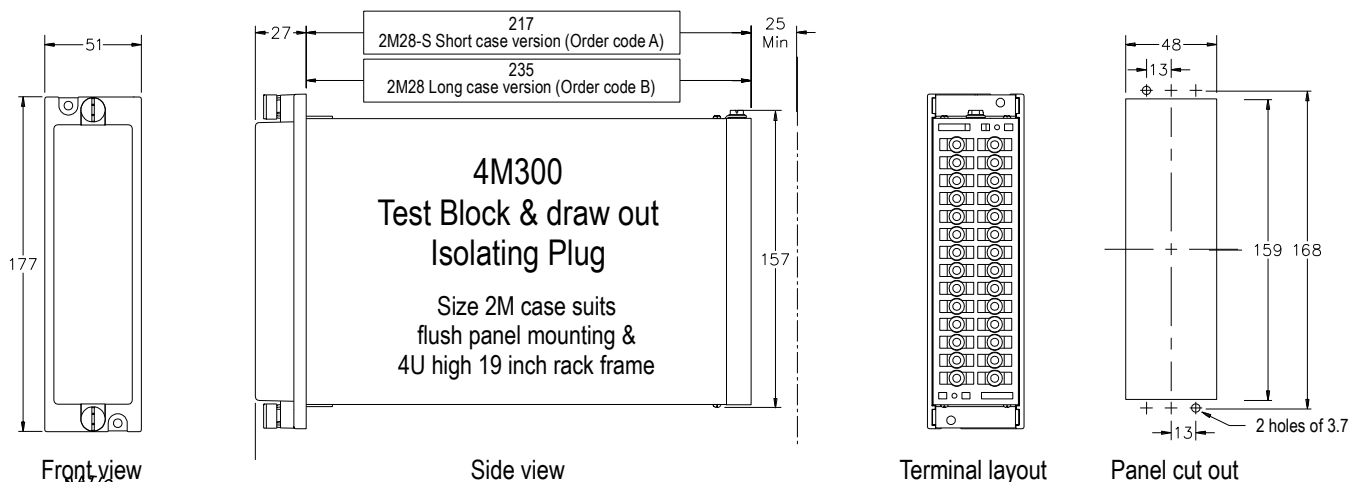

Figure 7: Case details

# Ordering Information

Generate the required ordering code as follows: e.g. 4M300-BA

**4M300** 1 2 **TEST BLOCK (SOCKET)**

- 1 AUXILIARY SUPPLY ISOLATING LINK**  
 A Not required (Isolation Plug not supplied)  
 B Required (Test Block supplied with Isolation Plug)
- 2 CASE LENGTH** (Match to 4M320 case length)  
 A Short Default  
 B Long

Generate the required ordering code as follows: e.g. 4M320-BA

**4M320** 1 2 **TEST PLUG**

- 1 CT SHORTING LINKS**  
 A Manual (External links to be fitted by operator)  
 B Automatic (Internal links fitted between terminals 21, 23, 25 & 27)
- 2 CASE LENGTH** (Match to 4M300 case length)  
 A Short Default  
 B Long

### TYPICAL APPLICATION OF 4M300 TEST BLOCK & 4M320 TEST PLUG

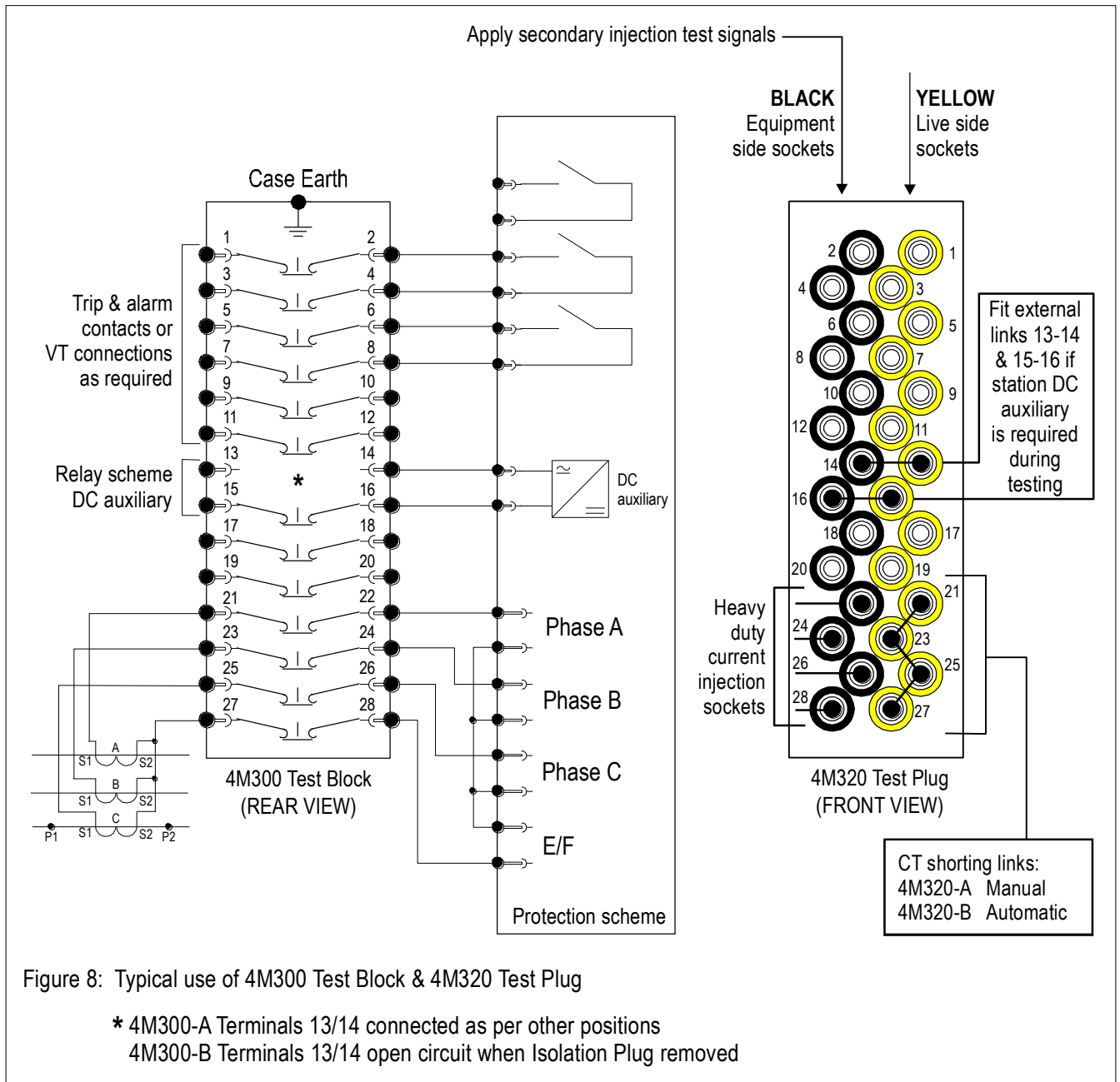



**RMS Mors Smitt**  
A Wabtec company

[www.rmspl.com.au](http://www.rmspl.com.au)



Relay Monitoring Systems Pty Ltd design, manufacture and market a wide range of electrical protection and control products for application on high voltage power systems. The company's depth of manufacturing and engineering expertise is backed up by many years of experience since the formation of its predecessor, Relays Pty Ltd (RPL), in 1955. This experience combined with a broad base of field proven product types enables RMS to service specific customer needs by producing relays on demand and with typically short lead times.

## Relay Monitoring Systems Pty Ltd

6 Anzed Court  
Mulgrave, Victoria 3170  
AUSTRALIA  
Ph: +61 3 8544 1200  
Fax +61 3 8544 1201  
Sales: [sales.rms@wabtec.com](mailto:sales.rms@wabtec.com)  
[www.rmspl.com.au](http://www.rmspl.com.au)  
[www.relays.com.au](http://www.relays.com.au)

### ISO9001 Quality Accreditation

RMS holds BSI (British Standards Institution) registration number FS 604860 for the certification of a quality system to AS/NZS ISO9001:2008.

Due to RMS continuous product improvement policy the information contained in this document is subject to change without prior notice.

© 2019 Relay Monitoring Systems Pty Ltd

ABN 76 052 484 483